

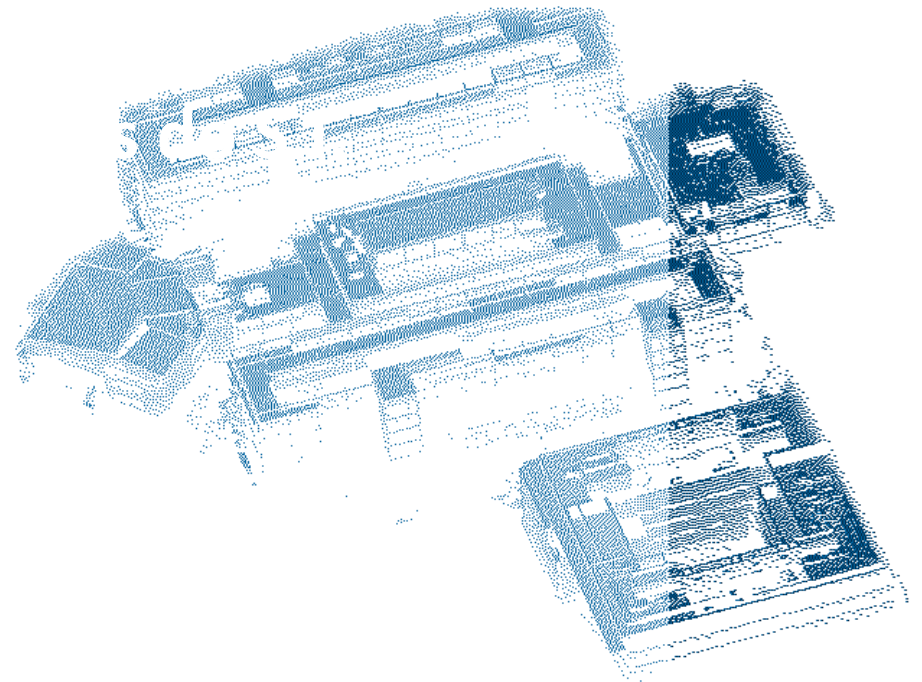

Ciências
ULisboa

Departamento de Física

Padrões e Cadeias de Rastreabilidade



Alexandre Cabral
Alexandre.Cabral@fc.ul.pt

Padrões e Cadeias de Rastreabilidade

- O que é um Padrão?
- O que é uma cadeia de Rastreabilidade?

padrão / measurement standard / étalon
padrão de medição / etalon / ---

realização da definição de uma dada **grandeza**, com um **valor** determinado e associado a uma **incerteza de medição**, tomado como referência

EXEMPLO 1: Massa-padrão de 1 kg com uma incerteza-padrão de medição associada de 3 μg .

EXEMPLO 2: Resistência-padrão de 100 Ω com uma incerteza-padrão de medição associada de 1 $\mu\Omega$.

EXEMPLO 3: Padrão de frequência de césio com uma incerteza-padrão relativa de medição associada de 2×10^{-15} .

EXEMPLO 4: Solução de referência com um valor de pH de 7,072 e com uma incerteza-padrão de medição associada de 0,006.

EXEMPLO 5: Conjunto de soluções de referência de cortisona no *serum* humano com um valor certificado e uma incerteza-padrão de medição para cada solução.

EXEMPLO 6: **Material de referência** fornecendo valores da grandeza com incertezas-padrão de medição para a concentração mássica para cada uma de dez proteínas diferentes.

Padrões e Cadeias de Rastreabilidade

- O que é um Padrão?
- O que é uma cadeia de Rastreabilidade?

rastreabilidade metrológica / metrological traceability / traçabilité métrologique

propriedade de um **resultado de medição** através da qual o resultado pode ser relacionado a uma referência por intermédio de uma cadeia ininterrupta e documentada de **calibrações**, cada uma contribuindo para a **incerteza de medição**

cadeia de rastreabilidade metrológica / metrological traceability chain / chaîne de traçabilité métrologique

cadeia de rastreabilidade / traceability chain / chaîne de traçabilité

sequência de **padrões e calibrações** que é usada para relacionar um **resultado de medição** a uma referência

NOTA 1 Uma cadeia de rastreabilidade metrológica é definida através de uma **hierarquia de calibração**.

NOTA 2 A cadeia de rastreabilidade metrológica é usada para estabelecer a **rastreabilidade metrológica** de um resultado de medição.

NOTA 3 Uma comparação entre dois padrões pode ser vista como uma calibração se a comparação for usada para verificar e, se necessário, corrigir o **valor da grandeza e a incerteza de medição** atribuídas a um dos padrões.

Padrões e Cadeias de Rastreabilidade

HIERARQUIA DO SISTEMA METROLÓGICO

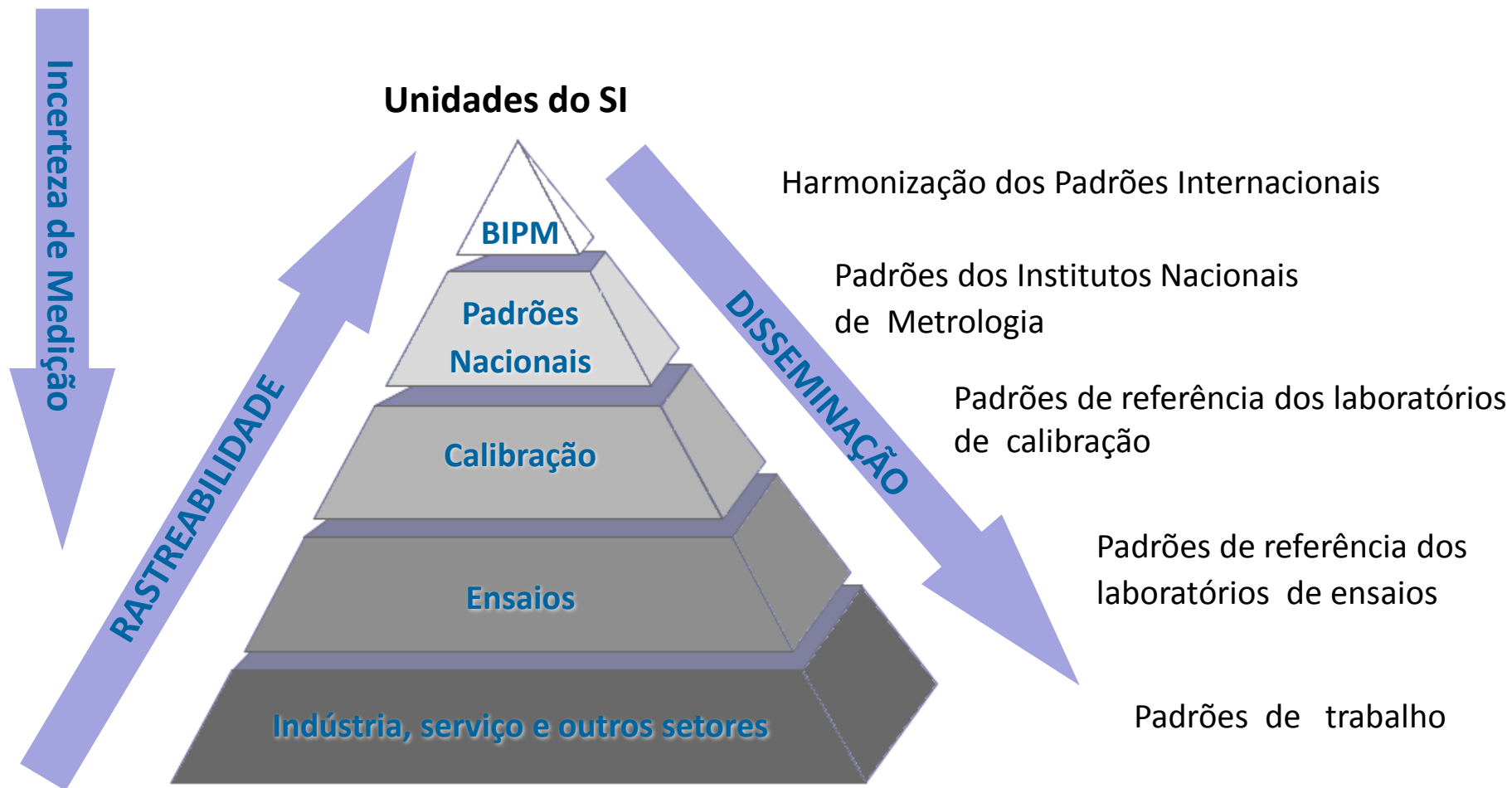

Padrões e Cadeias de Rastreabilidade

Exemplo dos Níveis de hierarquia de calibração para Medidores de deslocamento

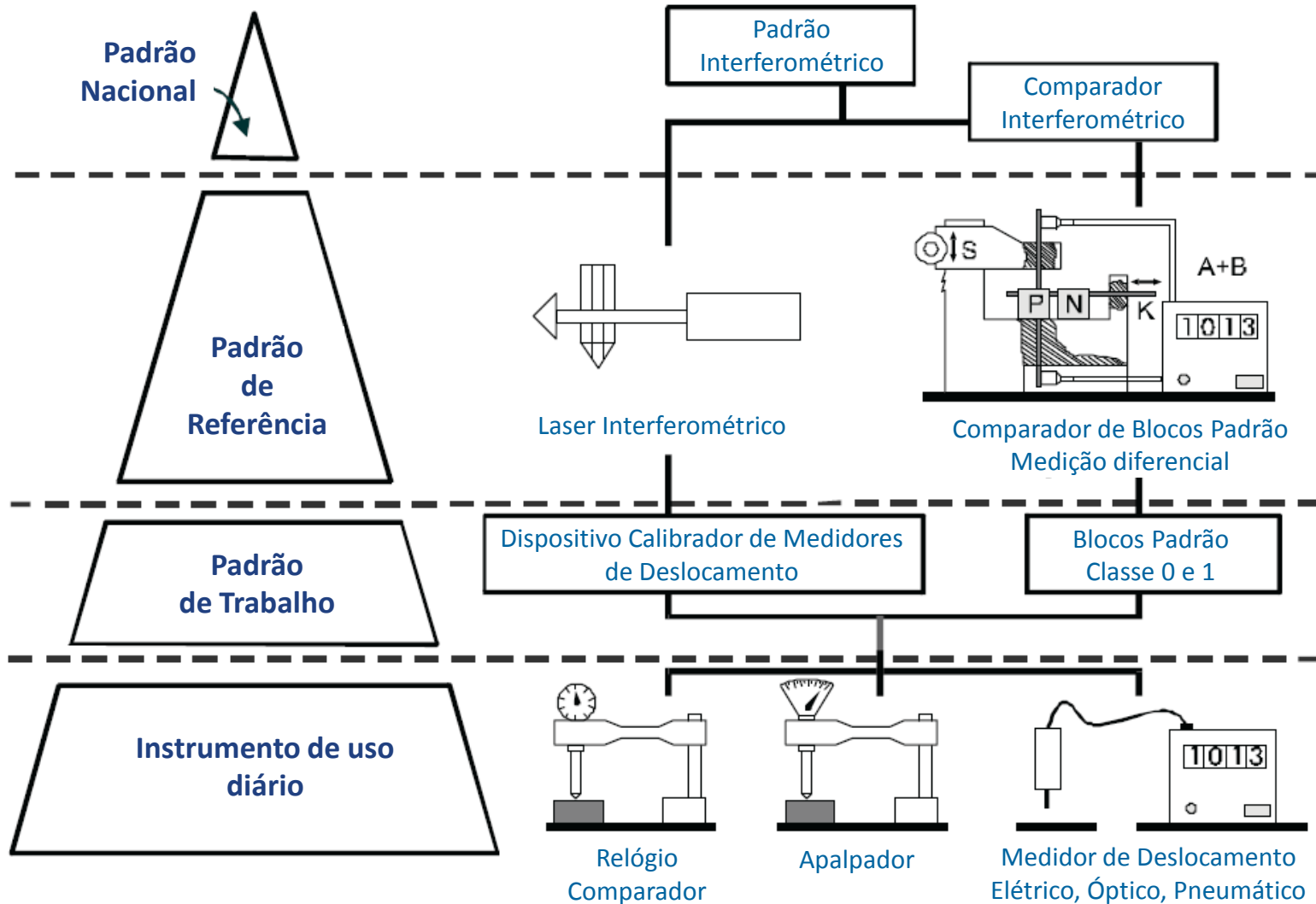

Padrões e Cadeias de Rastreabilidade

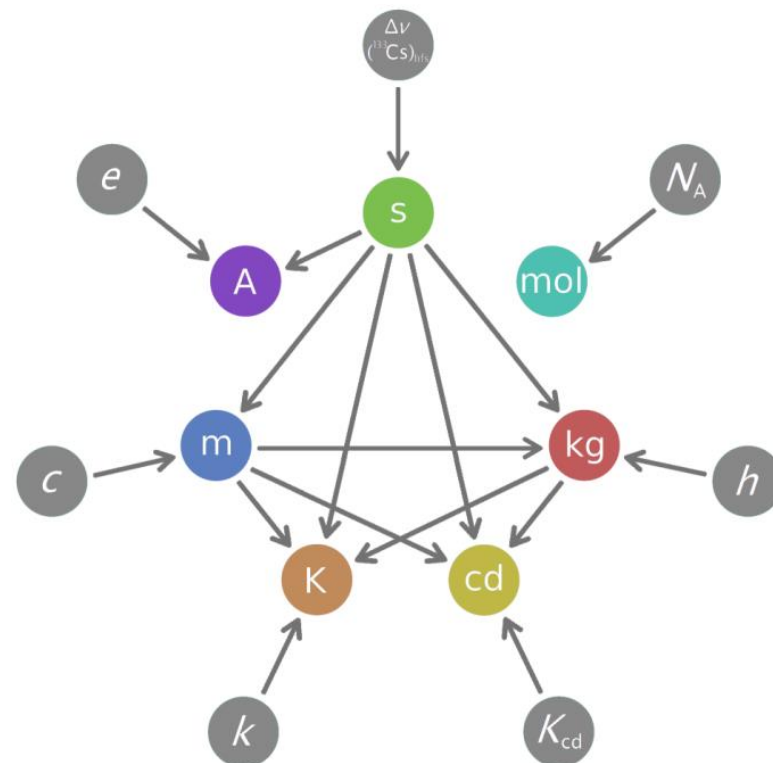

Avaliação da Disciplina

1a) Trabalho Escrito: Uma grandeza do SI 25%
1b) Apresentação: Uma grandeza do SI 20%
2) Apresentação: Análise crítica de um Artigo científico sobre metrologia				. 25%
3) Teste sobre as grandezas do SI 15%
4) Participação nas aulas 15%

NOTA:

Os alunos deverão formular questões no final das apresentações dos colegas!

Uma parte considerável do teste incidirá no conteúdo dos trabalhos escritos.

Caso não se realize o teste, a percentagem será diluída nos outros pontos de forma igual

Trabalhos a realizar pelos Alunos

1) Uma grandeza do SI

Trabalho sobre uma grandeza do SI, com enfoque nos aspetos relacionados com a Físico-Química, por exemplo:

- Evolução da grandeza no SI (e da sua definição)
- Realização Prática da Grandeza ... antes e depois do novo SI

Trabalho escrito com um mínimo de 1200 e máximo de 2000 palavras (sem contar com capa, índice e referências)

Apresentação do trabalho sobre a grandeza do SI, com uma duração máxima de 25 minutos

2) Análise crítica de um Artigo científico sobre metrologia

Apresentação com uma duração máxima de 20 minutos, onde devem ser focados:

- Estado da arte do tema
- Componente experimental e a Físico-Química que envolver o tema
- Conclusões com análise crítica por parte do aluno (do tema e do artigo)

Planeamento das Aulas

	Seg	Ter	Qua	Qui	Sex	Sab	Dom
Setembro	17	18	19	20	21	22	23
	Aula de apresentação			Introdução aos Padrões e Cadeias de Rastreabilidade			
	24	25	26	27	28	29	30
	Não há aula			O SI Definição dos Trabalhos			
Outubro	1	2	3	4	5	6	7
	Não há aula			Feriado			
	8	9	10	11	12	13	14
	Tempo e Frequência Dr. Carlos Pires (IPQ)			Aula de acompanhamento dos trabalhos			
	15	16	17	18	19	20	21
	Comprimento Dr. Fernanda Saraiva (IPQ)			Aula de acompanhamento dos trabalhos			
22	23	24	25	26	27	28	
Mole Doutora Florbela Dias (IPQ)			Temperatura Eng ^a Isabel Lóio (IPQ)				
29	30	31	1	2	3	4	
Avaliação de incerteza ... Doutor João A. Sousa (IPQ)			Massa Dr. Pedro Conceição (IPQ)				
Novembro	5	6	7	8	9	10	11
	Grandezas Eléctricas Doutora Isabel Godinho (IPQ)			Candela Doutor Olivier Pellegrino (IPQ)			
	12	13	14	15	16	17	18
	Aula de acompanhamento dos trabalhos			Apresentação dos trabalhos: s, m, mol			
19	20	21	22	23	24	25	
Apresentação dos trabalhos: K, kg			Apresentação dos trabalhos: A, Cd				
26	27	28	29	30	1	2	
Apresentação dos artigos: 1, 2 e 3			Apresentação dos artigos: 4, 5 e 6				
Dezembro	3	4	5	6	7	8	9
	Apresentação dos artigos: 7, 8 e 9			Apresentação dos artigos: 10, 11 e 12			
	10	11	12	13	14	15	16
Aula de dúvidas			Aula de dúvidas				
17	18	19	20	21	22	23	
(Se...então) Teste							

Tempo e Frequência Dr. Carlos Pires (IPQ)	10 de outubro
Comprimento Dr. Fernanda Saraiva (IPQ)	17 de outubro
Mole Doutora Florbela Dias (IPQ)	24 de outubro
Temperatura Eng ^a Isabel Lóio (IPQ)	26 de outubro
Avaliação de incerteza utilizando MMC Doutor João A. Sousa (IPQ)	31 de outubro
Massa Dr. Pedro Conceição (IPQ)	2 de novembro
Grandezas Eléctricas Doutora Isabel Godinho (IPQ)	7 de novembro
Candela Doutor Olivier Pellegrino (IPQ)	9 de novembro

Padrões e Cadeias de Rastreabilidade

■ Importância de ter um Sistema Internacional de Unidades

- O desenvolvimento da linguagem ...
- A necessidade de contar ...
- Só os números não bastam ...
- Unidades baseadas na anatomia ...
- O papel do Faraó e do Rei ...
- A busca por referências estáveis ...
- Finalmente, em 1960, a unificação ...

O cúbito do Faraó

distância do cotovelo até a ponta do dedo médio do Faraó



O pé médio da idade média

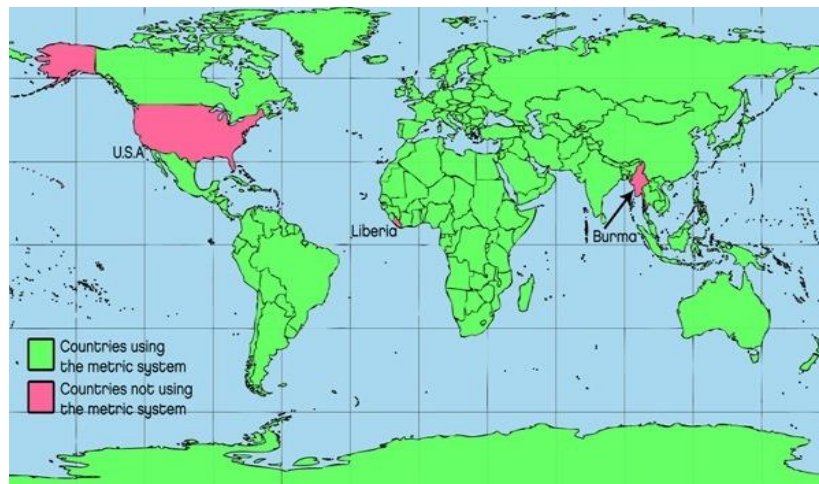

Unidades do Sistema Internacional

■ Unidades S.I.

Grandeza	Unidade	
	Nome	Símbolo
Comprimento	metro	m
Massa	quilograma	kg
Tempo	segundo	s
Intensidade de corrente eléctrica	ampere	A
Temperatura termodinâmica	kelvin	K
Quantidade de matéria	mole	mol
Intensidade luminosa	candela	cd

Unidades do Sistema Internacional

■ Unidades S.I. Derivadas

Grandeza	Unidade		Expressão	
	Nome	Símbolo	Em outras unidades SI	Em unidades SI de base ou suplementares
Ângulo plano	radiano	rad		$m \cdot m^{-1}$
Ângulo sólido	esterradiano	sr		$m^2 \cdot m^{-2}$
Frequência	hertz	Hz	-	s^{-1}
Força	newton	N	-	$m \cdot kg \cdot s^{-2}$
Pressão e tensão	pascal	Pa	$N \cdot m^{-2}$	$m^{-1} \cdot kg \cdot s^{-2}$
Energia, trabalho, quantidade de calor	joule	J	$N \cdot m$	$m^2 \cdot kg \cdot s^{-2}$
Potência, fluxo magnético	watt	W	$J \cdot s^{-1}$	$m^2 \cdot kg \cdot s^{-3}$
Quantidade de electricidade, carga eléctrica	coulomb	C	-	$s \cdot A$
Tensão eléctrica, potencial eléctrico, força electromotriz	volt	V	$W \cdot A^{-1}$	$m^2 \cdot kg \cdot s^{-3} \cdot A^{-1}$
Resistência eléctrica	ohm	Ω	$V \cdot A^{-1}$	$m^2 \cdot kg \cdot s^{-3} \cdot A^{-2}$
Condutância eléctrica	siemens	S	$A \cdot V^{-1}$	$m^{-2} \cdot kg^{-1} \cdot s^3 \cdot A^2$
Capacidade eléctrica	farad	F	$C \cdot V^{-1}$	$m^{-2} \cdot kg^{-1} \cdot s^4 \cdot A^2$
Fluxo de indução magnético	weber	Wb	$V \cdot s$	$m^2 \cdot kg \cdot s^{-2} \cdot A^{-1}$
Indução Magnética	tesla	T	$Wb \cdot m^{-2}$	$kg \cdot s^{-2} \cdot A^{-1}$
Indutância	henry	H	$Wb \cdot A^{-1}$	$m^2 \cdot kg \cdot s^{-2} \cdot A^{-2}$
Fluxo luminoso	lúmen	lm	-	$cd \cdot m \cdot m^{-1}$
Iluminação	lux	lx	$lm \cdot m^{-2}$	$m^{-2} \cdot cd \cdot m \cdot m^{-1}$
Actividades (raios ionizantes)	becquerel	Bq	-	s^{-1}
Dose absorvida	gray	Gy	$J \cdot kg^{-1}$	$m^2 \cdot s^{-2}$
Equivalente de dose	sievert	Sv	$J \cdot kg^{-1}$	$m^2 \cdot s^{-2}$

Unidades do Sistema Internacional

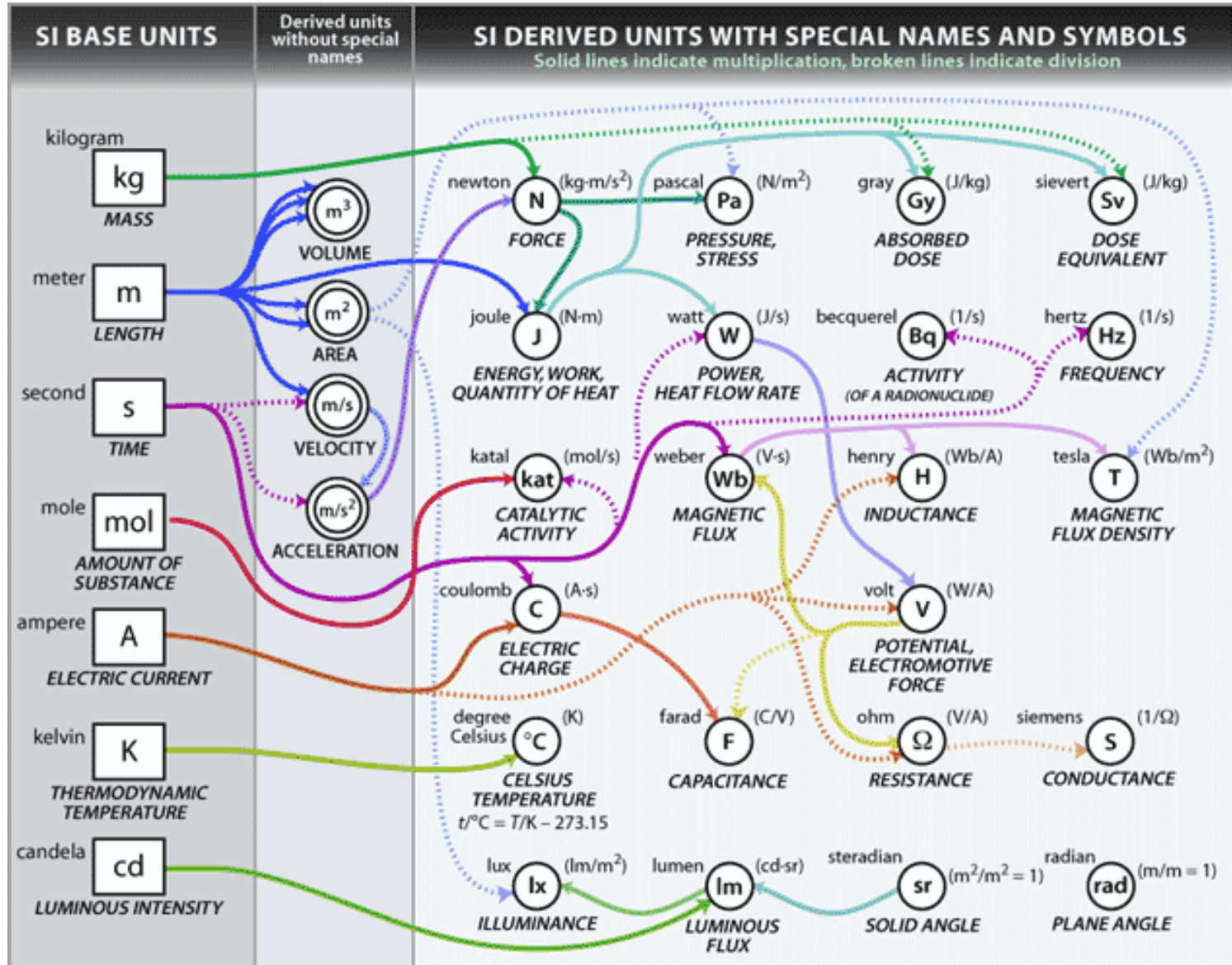

O exemplo da definição do metro ao longo do tempo

1ª Definição do metro (1793)

- Décima milionésima parte do quarto do meridiano terrestre que passa por Paris.

2ª Definição do metro (1799)

- Distância entre os topos de uma barra de platina a 0 °C.

3ª Definição do metro (1889)

- Distância entre dois traços centrais marcados numa barra de platina iridiada, de secção em “X”, à temperatura de 0 °C.

4ª Definição do metro (1960)

- Comprimento igual a 1 650 763,73 comprimentos de onda, no vácuo, da radiação correspondente à transição entre os níveis 2p e 5d do átomo de cripton-86.

5ª Definição do metro (1983)

- O metro é o comprimento do trajeto percorrido pela luz no vácuo durante um intervalo de tempo de 1/299 792 458 do segundo.

6ª ????



A Convenção do Metro

- Em meados do século XIX tornou-se premente a necessidade da existência de um sistema métrico decimal universal, particularmente, durante a primeira exposição universal.
- Em 20 de Maio de 1875, ocorreu em Paris uma Conferência Diplomática sobre o metro, onde 17 governos, incluindo Portugal, assinaram um tratado "A Convenção do Metro".
- Os signatários decidiram criar e financiar um instituto científico e permanente: o "Bureau International des Poids et Mesures", BIPM.
- Temos assim o **BIPM**, uma organização intergovernamental sob a autoridade da Conferência Geral de Pesos e Medidas (CGPM, Conférence générale des poids et mesures) e a supervisão do o Comité Internacional de Pesos e Medidas (CIPM, Comité international des poids et mesures).
- A CGPM, discute e examina o trabalho executado pelos Laboratórios Nacionais de Metrologia, e o BIPM faz recomendações sobre novas determinações da metrologia fundamental e em todos os outros domínios de atuação do BIPM.

Organização da Convenção do Metro

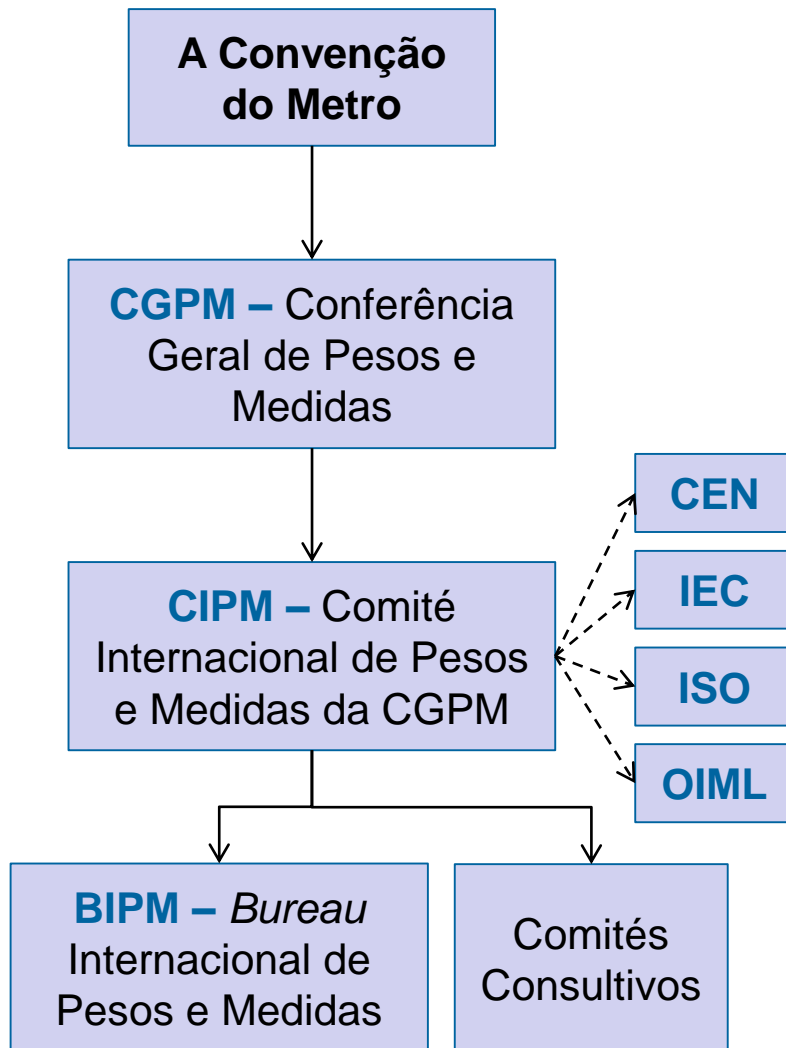

- **CGPM** - Aprova o SI e os resultados da investigação metrológica fundamental
- **CIPM** - Coopera com outras organizações metrológicas internacionais
- **BIPM** - Realiza investigação internacional em unidades físicas e em padrões
 - Administra as comparações inter-laboratoriais entre os laboratórios primários nacionais

O portal do BIPM

www.bipm.org

The screenshot shows the BIPM website interface. At the top, there is a navigation bar with links for 'ABOUT US', 'WORLDWIDE METROLOGY', 'INTERNATIONAL EQUIVALENCE', 'MEASUREMENT UNITS', 'SERVICES', 'PUBLICATIONS', and 'MEETINGS'. Below this, the main content area features a large image of gold-colored capacitor components. To the right of the image is a 'Metrology area:' section with a list of categories: Acoustics, Ultrasound and Vibration; Chemistry and Biology; Electricity and Magnetism; Ionizing Radiation; Length; Mass and related quantities; Photometry and Radiometry; Thermometry; Time and Frequency; and Units. Below the image, there is a yellow banner with a clock icon and text: 'UTC Date: Thursday 24 September UTC 21:48:30 Your estimated transmission delay: 0.13 second(s)'. At the bottom, there is a 'BIPM News:' section with three news items, and a 'The BIPM's mission and role:' section with a paragraph and a bulleted list of goals.

Bureau International des Poids et Mesures – the intergovernmental organization through which Member States act together on matters related to measurement science and measurement standards.

Search facility:

Site map | News | Contact us | [FR]

ABOUT US WORLDWIDE METROLOGY INTERNATIONAL EQUIVALENCE MEASUREMENT UNITS SERVICES PUBLICATIONS MEETINGS

About the BIPM



BIPM calculable capacitor: mounts for the electrode bars

Metrology area:

- Acoustics, Ultrasound and Vibration
- Chemistry and Biology
- Electricity and Magnetism
- Ionizing Radiation
- Length
- Mass and related quantities
- Photometry and Radiometry
- Thermometry
- Time and Frequency
- Units

UTC Date: Thursday 24 September UTC 21:48:30
Your estimated transmission delay: 0.13 second(s)

[International time](#)

BIPM News:

- Graphene-based QHE measurements
The use of graphene to greatly simplify the quantum Hall effect (QHE) standard for electrical resistance calibrations is getting closer to reality. Read about the latest measurements at the BIPM.
- First comparisons of ^{18}F activity using the SIR Transfer Instrument
These successful comparisons took place in 2014 at the VNIIM, NPL and ENEA-LNMRI and their results were presented at the International Committee for Radionuclide Metrology (ICRM) conference in Vienna in June 2015.
- JCTLM session on 'Metrology and Standardization in Laboratory Diagnostics' at EuroMedLab 2015
The JCTLM organized a session on 'Metrology and Standardization in Laboratory Diagnostics' at EuroMedLab Paris 2015, one of the world's largest meetings on clinical laboratory metrology.

The BIPM's mission and role:

The mission of the BIPM is to ensure and promote the global comparability of measurements, including providing a coherent international system of units for:

- Scientific discovery and innovation,
- Industrial manufacturing and international trade,
- Sustaining the quality of life and the global environment.

The unique role of the BIPM enables it to achieve its mission by developing the technical and organizational infrastructure of the International System of Units (SI) as the basis for the world-wide traceability of measurement results. This is achieved both through technical activities in its laboratories

The screenshot shows a dropdown menu for 'PUBLICATIONS' on the BIPM website. The menu is open, displaying a list of links. The top navigation bar includes 'MEASUREMENT UNITS', 'SERVICES', and 'PUBLICATIONS'. The dropdown menu contains the following items: 'The International System of Units (SI)', 'Unit definitions', 'SI prefixes', 'How to realize the definitions in practice', 'SI Brochure', 'Decisions of the CGPM and the CIPM', 'Consultative Committee for Units (CCU)', 'CODATA Task Group on Fundamental Constants', 'On the future revision of the SI', and 'Brief history of the SI'. Below the main content area, there is another navigation bar with 'PUBLICATIONS' and 'MEETINGS' highlighted. A second dropdown menu is open under 'PUBLICATIONS', showing links to 'SI Brochure', 'Mises en pratique', 'Annual Director's Report', 'Rapport aux Gouvernements', 'Notification of Contributions', 'Official proceedings', 'Resolutions of the General Conference', 'Scientific output', 'Metrologia', and 'Guides in Metrology'.

Site map | News | Cor

MEASUREMENT UNITS SERVICES PUBLICATIONS

The International System of Units (SI)

Unit definitions

SI prefixes

How to realize the definitions in practice

SI Brochure

Decisions of the CGPM and the CIPM

Consultative Committee for Units (CCU)

CODATA Task Group on Fundamental Constants

On the future revision of the SI

Brief history of the SI

Site map | news | Contact us | [FR]

PUBLICATIONS MEETINGS

SI Brochure

Mises en pratique

Annual Director's Report

Rapport aux Gouvernements

Notification of Contributions

Official proceedings

Resolutions of the General Conference

Scientific output

Metrologia

Guides in Metrology

On the future revision of the SI

Future revision of the SI

What?

Why?

When?

Ongoing work

Key documents

FAQs; More info.

→ At its 25th meeting (November 2014) the CGPM adopted a Resolution on the future revision of the International System of Units. This Resolution built on the CGPM's previous Resolution (2011), which took note of the CIPM's intention to propose a revision of the SI and set out a detailed roadmap towards the future changes.

In the revised SI four of the SI base units - namely the kilogram, the ampere, the kelvin and the mole - will be redefined in terms of constants; the new definitions will be based on fixed numerical values of the Planck constant (h), the elementary charge (e), the Boltzmann constant (k_B), and the Avogadro constant (N_A), respectively. Further, the definitions of all seven base units of the SI will also be uniformly expressed using the explicit-constant formulation, and specific *mises en pratique* will be drawn up to explain the realization of the definitions of each of the base units in a practical way.



- Information for users about the proposed revision of the SI
- SI roadmap (updated 2018)
- Draft Resolution A "On the revision of the International System of units (SI)" to be submitted to the CGPM at its 26th meeting (2018)
- Resolution 1 of the CGPM (2014): On the future revision of the International System of Units, the SI
- Resolution 1 of the CGPM (2011): On the possible future revision of the International System of Units, the SI

On the future revision of the SI

Future revision of the SI [What?](#) [Why?](#) [When?](#) [Ongoing work](#) [Key documents](#) [FAQs; More info.](#)

→ In the revised SI all units are defined in terms of a set of seven reference constants, to be known as the "defining constants of the SI", namely the caesium hyperfine splitting frequency, the speed of light in vacuum, the Planck constant, the elementary charge (i.e. the charge on a proton), the Boltzmann constant, the Avogadro constant, and the luminous efficacy of a specified monochromatic source.

This results in a simpler and more fundamental definition of the entire SI, and dispenses with the last of the definitions based on a material artefact – the international prototype of the kilogram.

Draft Resolution A: On the revision of the International System of units (SI)

It is expected that in November 2018 the CGPM at its 26th meeting will adopt a revision of the SI in which:

- the unperturbed ground state hyperfine transition frequency of the caesium 133 atom $\Delta\nu_{\text{Cs}}$ is 9 192 631 770 Hz,
- the speed of light in vacuum c is 299 792 458 m/s,
- the Planck constant h is $6.626\,070\,15 \times 10^{-34}$ J s,
- the elementary charge e is $1.602\,176\,634 \times 10^{-19}$ C,
- the Boltzmann constant k is $1.380\,649 \times 10^{-23}$ J/K,
- the Avogadro constant N_{A} is $6.022\,140\,76 \times 10^{23}$ mol⁻¹,
- the luminous efficacy of monochromatic radiation of frequency 540×10^{12} Hz, K_{cd} , is 683 lm/W,

where

- the hertz, joule, coulomb, lumen, and watt, with unit symbols Hz, J, C, lm, and W, respectively, are related to the units second, metre, kilogram, ampere, kelvin, mole, and candela, with unit symbols s, m, kg, A, K, mol, and cd, respectively, according to $\text{Hz} = \text{s}^{-1}$, $\text{J} = \text{m}^2 \text{kg s}^{-2}$, $\text{C} = \text{s A}$, $\text{lm} = \text{cd m}^2 \text{m}^{-2} = \text{cd sr}$, and $\text{W} = \text{m}^2 \text{kg s}^{-3}$,
- the numerical values of h , e , k , and N_{A} are based on the most recent CODATA adjustment.



On the future revision of the SI

Future revision of the SI What? Why? When? Ongoing work Key documents FAQs; More info.

→ In the revised SI all units are defined in terms of a set of seven reference constants, to be known as the "defining constants of the SI", namely the caesium hyperfine splitting frequency, the speed of light in vacuum, the Planck constant, the elementary charge (i.e. the charge on a proton), the Boltzmann constant, the Avogadro constant, and the luminous efficacy of a specified monochromatic source.

This results in a simpler and more fundamental definition of the entire SI, and dispenses with the last of the definitions based on a material artefact - the international prototype of the kilogram.

Draft Resolution A: On the revision of the International System of units (SI)

It is expected that in November 2018 the CGPM at its 26th meeting will adopt a revision of the SI in which:

- o the unperturbed ground state hyperfine transition frequency of the caesium 133 atom $\Delta\nu_{\text{Cs}}$ is 9 192 631 770 Hz,
- o the speed of light in vacuum c is 299 792 458 m/s,
- o the Planck constant h is $6.626\,070\,15 \times 10^{-34}$ J s,
- o the elementary charge e is $1.602\,176\,634 \times 10^{-19}$ C,



- o the Boltzmann constant k_{B} is $1.380\,650\,4 \times 10^{-23}$ J K⁻¹,
- o the Avogadro constant N_{A} is $6.022\,140\,76 \times 10^{23}$ mol⁻¹,
- o the luminous efficacy of a specified monochromatic source K_{m} is 683 lm/W,

where

- i. the hertz, joule, second, ampere, kelvin, mole, and candela, with $\text{Hz} = \text{s}^{-1}$, $\text{J} = \text{m}^2 \text{kg s}^{-2}$, $\text{C} = \text{s A}$, $\text{lm} = \text{cd m}^2 \text{m}^{-2} = \text{cd sr}$, and $\text{W} = \text{m}^2 \text{kg s}^{-3}$,
- ii. the numerical values of h , e , k_{B} , and N_{A} are based on the most recent CODATA adjustment.

For full details the reader is referred to the formal texts of the adopted Resolutions:

- Resolution 1 of the CGPM (2014):
On the future revision of the International System of Units, the SI
- Resolution 1 of the CGPM (2011):
On the possible future revision of the International System of Units, the SI
- Resolution 12 of the CGPM (2007):
On the possible redefinition of certain base units of the International System of Units (SI)

On the future revision of the SI

Future revision of the SI What? Why? When? Ongoing work Key documents FAQs; More info.

→ The revision of the SI will ensure that the SI continues to meet the needs of science, technology, and commerce in the 21st century.

Of the seven base units of the SI, only the kilogram is still defined in terms of a material artefact, namely the international prototype kept at the BIPM. The major disadvantage of the present definition of the kilogram is that it refers to the mass of the artefact which, by its very nature, we know cannot be absolutely stable.

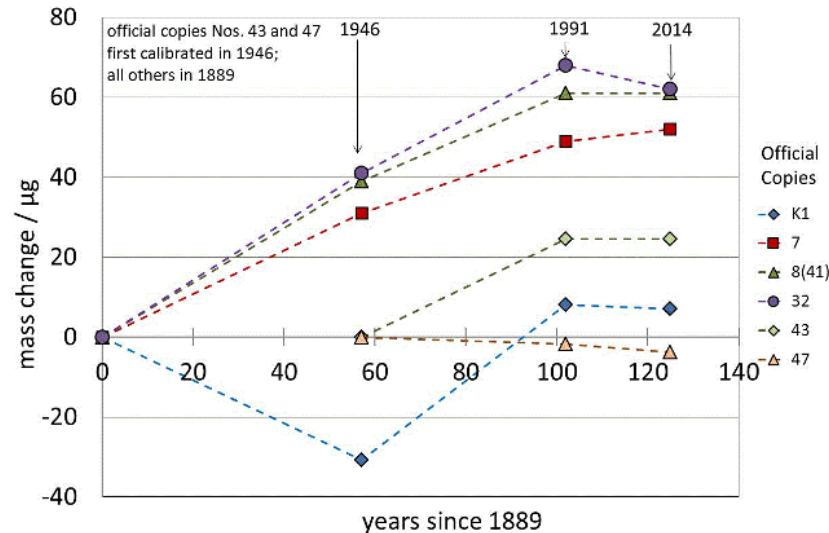

The results of comparisons between the official copies and the international prototype show some divergence with time. The graph opposite shows changes of about 5 parts in 10^8 , equivalent to 50 μg , in the mass of the standards since their first calibration more than 100 years ago. Note that this graph shows only the relative changes from the mass of the international prototype (corresponding to the zero value of the y-axis). The drift in the mass of the international prototype itself since 1889 cannot be shown but it must certainly be present. The rate of change of its mass can be determined only by absolute experiments which up to now are of insufficiently high precision.

Unknown changes in the mass unit also influence the electrical units, because the definition of the ampere is related to the kilogram. Similarly, the definitions of the mole and candela also depend on the kilogram.

O portal do BIPM



CCM conditions (before redefinition)

CCM and CCU roadmap for the revised

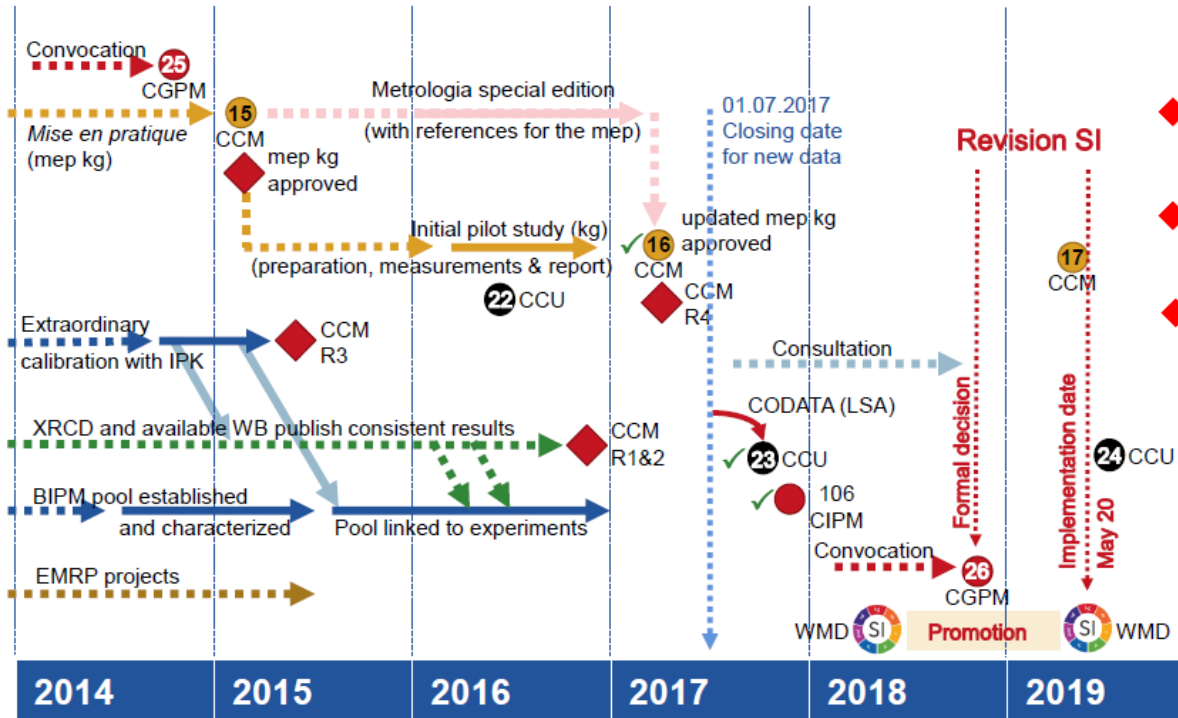

- ◆ **R1 Consistency**
Three independent experiments (XRCD & WB) with consistent results with $u_{rel} < 5 \cdot 10^{-8}$
- ◆ **R2 Uncertainty**
at least one result with $u_{rel} < 2 \cdot 10^{-8}$
- ◆ **R3 Traceability**
Extraordinary calibration with IPK @ BIPM
- ◆ **R4 Validation**
Validation of the *mise en pratique* according to the CIPM-MRA

Há um draft de
uma nova
edição de
2018!

1 Introduction

- 1.1 Quantities and units
- 1.2 The International System of Units (SI) and the corresponding system of quantities
- 1.3 Dimensions of quantities
- 1.4 Coherent units, derived units with special names, and the SI prefixes
- 1.5 SI units in the framework of general relativity
- 1.6 Units for quantities that describe biological effects
- 1.7 Legislation on units
- 1.8 Historical note

2 SI units

- 2.1 SI base units
 - 2.1.1 Definitions
 - 2.1.1.1 Unit of length (metre)
 - 2.1.1.2 Unit of mass (kilogram)
 - 2.1.1.3 Unit of time (second)
 - 2.1.1.4 Unit of electric current (ampere)
 - 2.1.1.5 Unit of thermodynamic temperature (kelvin)
 - 2.1.1.6 Unit of amount of substance (mole)
 - 2.1.1.7 Unit of luminous intensity (candela)
 - 2.1.2 Symbols for the seven base units
- 2.2 SI derived units
 - 2.2.1 Derived units expressed in terms of base units
 - 2.2.2 Units with special names and symbols; units that incorporate special names and symbols
 - 2.2.3 Units for dimensionless quantities, also called quantities of dimension one

3 Decimal multiples and submultiples of SI units

- 3.1 SI prefixes
- 3.2 The kilogram

4 Units outside the SI

- 4.1 Non-SI units accepted for use with the SI, and units based on fundamental constants
- 4.2 Other non-SI units not recommended for use

5 Writing unit symbols and names, and expressing the values of quantities

- 5.1 Unit symbols
- 5.2 Unit names
- 5.3 Rules and style conventions for expressing values of quantities
 - 5.3.1 Value and numerical value of a quantity, and the use of quantity calculus
 - 5.3.2 Quantity symbols and unit symbols
 - 5.3.3 Formatting the value of a quantity
 - 5.3.4 Formatting numbers, and the decimal marker
 - 5.3.5 Expressing the measurement uncertainty in the value of a quantity
 - 5.3.6 Multiplying or dividing quantity symbols, the values of quantities, or numbers
 - 5.3.7 Stating values of dimensionless quantities, or quantities of dimension one

Appendix 1. — Decisions of the CGPM and the CIPM

Appendix 2. — Practical realization of the definitions of some important units

Appendix 3. — Units for photochemical and photobiological quantities



Realização prática das Unidades do S.I.

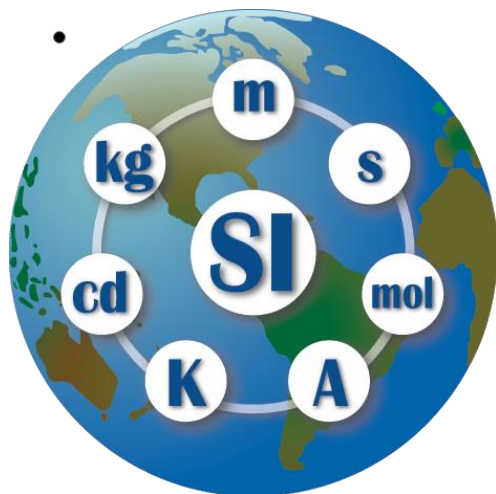

length

metre, m: The metre is the length of the path travelled by light in vacuum during a time interval of $1/299\,792\,458$ of a second.

It follows that the speed of light in vacuum, c_0 , is $299\,792\,458$ m/s exactly.

mass

kilogram, kg: The kilogram is the unit of mass; it is equal to the mass of the international prototype of the kilogram.

It follows that the mass of the international prototype of the kilogram, $m(\mathcal{K})$, is always 1 kg exactly.

time

second, s: The second is the duration of $9\,192\,631\,770$ periods of the radiation corresponding to the transition between the two hyperfine levels of the ground state of the caesium 133 atom.

It follows that the hyperfine splitting in the ground state of the caesium 133 atom, $\nu(\text{hfs Cs})$, is $9\,192\,631\,770$ Hz exactly.

electric current

ampere, A: The ampere is that constant current which, if maintained in two straight parallel conductors of infinite length, of negligible circular cross-section, and placed 1 metre apart in vacuum, would produce between these conductors a force equal to 2×10^{-7} newton per metre of length.

It follows that the magnetic constant, μ_0 , also known as the permeability of free space is $4\pi \times 10^{-7}$ H/m exactly.

thermodynamic temperature

kelvin, K: The kelvin, unit of thermodynamic temperature, is the fraction $1/273.16$ of the thermodynamic temperature of the triple point of water.

It follows that the thermodynamic temperature of the triple point of water; T_{tpw} , is 273.16 K exactly.

amount of substance

mole, mol:

1. The mole is the amount of substance of a system which contains as many elementary entities as there are atoms in 0.012 kilogram of carbon 12.
2. When the mole is used, the elementary entities must be specified and may be atoms, molecules, ions, electrons, other particles, or specified groups of such particles.

It follows that the molar mass of carbon 12, $M(^{12}\text{C})$, is 12 g/mol exactly.

luminous intensity

candela, cd: The candela is the luminous intensity, in a given direction, of a source that emits monochromatic radiation of frequency 540×10^{12} hertz and that has a radiant intensity in that direction of $1/683$ watt per steradian.

It follows that the spectral luminous efficacy, K , for monochromatic radiation of frequency 540×10^{12} Hz is 683 lm/W exactly.

Realização prática das Unidades do S.I.

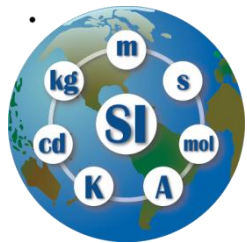

length

metre, m: The metre is the length of the path travelled by light in vacuum during a time interval of $1/299\,792\,458$ of a second.

Comprimento

It follows that the speed of light in vacuum, c_0 , is $299\,792\,458$ m/s exactly.

- O Comité Internacional de Pesos e Medidas (CIPM) adotou, em 1997, a Recomendação 1 (CI-1997), que especifica e atualiza as regras para realização prática da definição do metro:

Recomendação 1 (CI - 1983 - Realização Prática da Definição do Metro)

- que o metro seja realizado por um dos métodos seguintes:
 - a) por meio do comprimento l do trajeto percorrido no vácuo por uma onda eletromagnética plana durante um intervalo de tempo t ; este comprimento é obtido a partir da medição do intervalo de tempo t , utilizando a relação $l = c_0 t$ e o valor da velocidade da luz no vácuo $c_0 = 299\,792\,458$ m/s;
 - b) por meio do comprimento de onda no vácuo λ , de uma onda eletromagnética plana de frequência f ; este comprimento de onda é obtido a partir da medida da frequência f , utilizando a relação $\lambda = c_0 / f$ e o valor da velocidade da luz no vácuo $c_0 = 299\,792\,458$ m/s;
 - c) por meio de uma das radiações da lista seguinte, radiações para as quais se pode utilizar o valor dado do comprimento de onda no vácuo ou da frequência, com incerteza indicada, providenciando-se a observação das condições especificadas e o modo de procedimento reconhecido como apropriado;

Realização prática das Unidades do S.I.

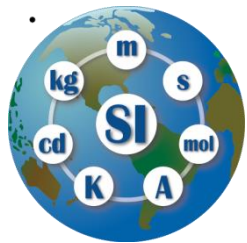

length

metre, m: The metre is the length of the path travelled by light in vacuum during a time interval of $1/299\,792\,458$ of a second.

Comprimento

It follows that the speed of light in vacuum, c_0 , is $299\,792\,458$ m/s exactly.

- O Comité Internacional de Pesos e Medidas (CIPM) adotou, em 1997, a Recomendação 1 (CI-1997), que especifica e atualiza as regras para realização prática da definição do metro:

Recomendação 1 (CI - 1983 - Realização Prática da Definição do Metro)

- que o metro seja realizado por um dos métodos seguintes:
 - que em todos os casos as correções necessárias sejam aplicadas levando em conta as condições reais, tais como difração, gravitação ou imperfeição do vácuo.
 - que o CIPM recomendou uma lista de radiações, com esse objetivo; lembrando, também, que, em 1992, o CIPM elaborou a revisão da realização prática da definição do metro;

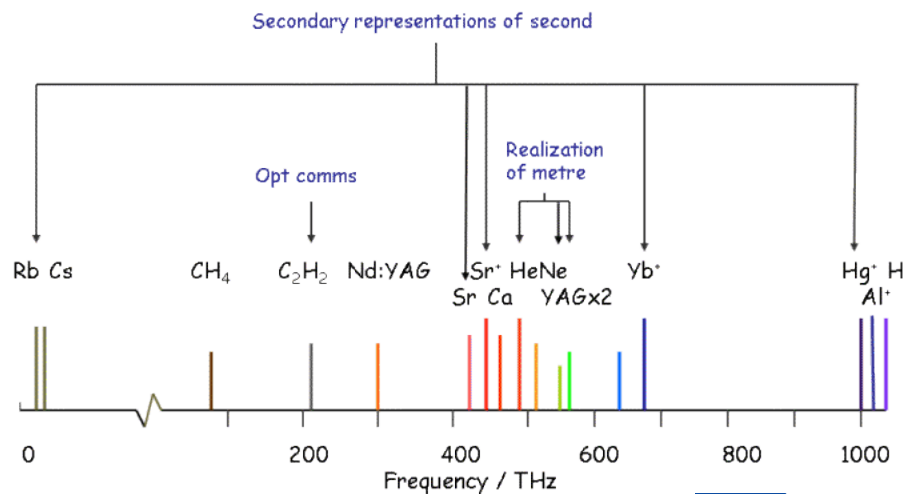

Realização prática das Unidades do S.I.

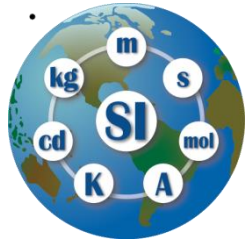

length

Comprimento

metre, m: The metre is the length of the path travelled by light in vacuum during a time interval of $1/299\,792\,458$ of a second.

It follows that the speed of light in vacuum, c_0 , is $299\,792\,458$ m/s exactly.

- O Comitê Internacional de Pesos e Medidas (CIPM) adotou, em 1997, a Recomendação 1 (CI-1997), que especifica e atualiza as regras para realização prática da definição do metro:

Recomendação 1 (CI - 1983 - Realização Prática da Definição do Metro)

- recomenda:

- que a nota seguinte, referente à relatividade geral, seja adicionada às regras para realização do metro:

No contexto da relatividade geral, o metro é considerado como uma unidade de comprimento própria. Então, a sua definição aplica-se, somente, num domínio espacial suficientemente pequeno, para o qual os efeitos da não uniformidade do campo gravitacional podem ser ignorados. Nesse caso, os únicos efeitos considerados são os efeitos da relatividade restrita.

Os métodos locais para realização do metro recomendado em b) e c), fornecem o metro próprio. O método recomendado em a) deverá, então, ser restrito a comprimentos l suficientemente curtos, para que os efeitos previstos pela relatividade geral sejam desprezáveis em relação às incertezas de medição.

Realização prática das Unidades do S.I.

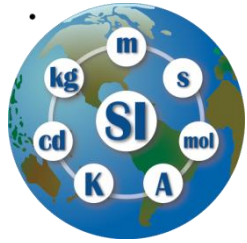

mass

kilogram, kg: The kilogram is the unit of mass; it is equal to the mass of the international prototype of the kilogram.

It follows that the mass of the international prototype of the kilogram, $m(\mathcal{K})$, is always 1 kg exactly.

Massa

- A unidade de massa, o quilograma, é a massa do protótipo internacional do quilograma confiado ao BIPM. É um cilindro, constituído de uma liga de 90% em massa de platina e 10% em massa de irídio. A massa dos padrões secundários do quilograma, em platina iridiada ou em aço inoxidável, é comparada à massa do protótipo internacional por meio de balanças, cuja incerteza relativa pode alcançar 1×10^{-9} .
- O aumento relativo da massa do protótipo internacional é de, aproximadamente, 1×10^{-9} , em razão do acumular inevitável de poluentes na superfície. Por esse motivo, o Comité Internacional declarou que, até uma mais completa informação, a massa do protótipo internacional é aquela que segue imediatamente à limpeza-lavagem segundo um método específico (PV, 1989, 57, 15-16 e PV, 1990, 58, 10-12).
- Massa do protótipo internacional do quilograma
= $1 \text{ kg} + 0.0368 d \text{ } \mu\text{g}$ em que d são os dias depois da limpeza



Realização prática das Unidades do S.I.

ASSINATURAS JORNAL DO DIA EMPREGO SERVIÇOS ▾

Ciência
P



Iniciar sessão ▾

Registrar

PORTUGAL ECONOMIA MUNDO CULTURA DESPORTO **CIÊNCIA** TECNOLOGIA OPINIÃO MULTIMÉDIA

Público de 22.01.2013

ESPAÇO MEDICINA ECOSFERA

O quilograma ganhou peso e agora tem de fazer dieta no solário

PÚBLICO 07/01/2013 - 15:59

Ao longo das décadas, o quilograma, que é referência internacional para se definir a massa, tem acumulado contaminantes e, por isso, tem aumentado de peso. Uma equipa está a tentar encontrar uma solução com raios ultravioletas e ozono.



O quilograma original que está em Paris DR

ASSINE JÁ

PUB

ÚLTIMAS NOTÍCIAS >

20:33 Conselho Europeu de Investigação atribui 680 milhões de euros em bolsas

Realização prática das Unidades do S.I.

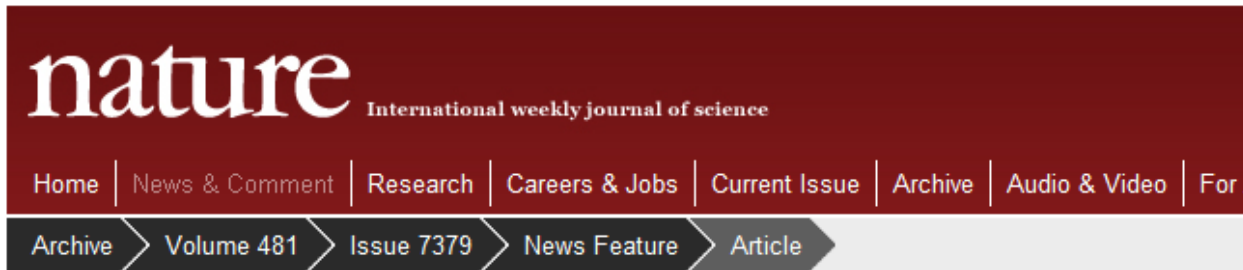

NATURE | NEWS FEATURE



Frontier experiments: Tough science

Five experiments as hard as finding the Higgs.

Nicola Jones

04 January 2012 | Clarified: 05 January 2012

1. Spotting distant signs of life
2. Seeing through the molecular mirror
3. Looking for extra dimensions
4. Catching a gravity wave
5. Redefining the kilogram

Realização prática das Unidades do S.I.

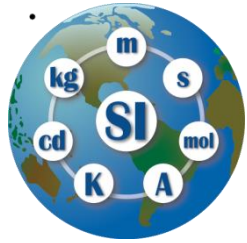

time

second, s: The second is the duration of 9 192 631 770 periods of the radiation corresponding to the transition between the two hyperfine levels of the ground state of the caesium 133 atom.

It follows that the hyperfine splitting in the ground state of the caesium 133 atom, $\nu(\text{hfs Cs})$, is 9 192 631 770 Hz exactly.

Tempo

- Um pequeno número de laboratórios nacionais de metrologia do tempo realizam a unidade de tempo com uma altíssima exatidão, a partir de padrões primários de frequência que produzem oscilações elétricas, cuja frequência está numa relação conhecida com a frequência de transição do átomo de césio 133 que define o segundo.
- Em 1997, os melhores desses padrões realizaram o segundo do SI com uma incerteza padrão relativa de 2×10^{-15} .
- Esta realização deve ser feita num laboratório suficientemente pequeno para permitir que os efeitos da não uniformidade do campo gravitacional sejam desprezáveis quando comparados a incertezas da realização do segundo.
- Note-se que o próprio segundo é obtido aplicando-se uma correção para a velocidade do átomo no laboratório, conforme a relatividade restrita.

Realização prática das Unidades do S.I.

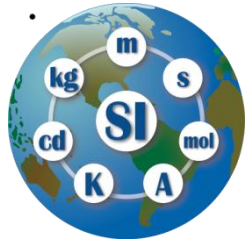

time

second, s: The second is the duration of 9 192 631 770 periods of the radiation corresponding to the transition between the two hyperfine levels of the ground state of the caesium 133 atom.

It follows that the hyperfine splitting in the ground state of the caesium 133 atom, $\nu(\text{hfs Cs})$, is 9 192 631 770 Hz exactly.

Tempo

- Os padrões primários de frequência permitem, também, calibrar a frequência dos padrões secundários de Tempo utilizados nos centros de referência nacionais.
- São geralmente relógios comerciais de césio que se distinguem por uma estabilidade a longo termo: capazes de manter uma frequência com estabilidade relativa melhor que 10^{-14} em períodos de vários meses.
- Os laboratórios nacionais possuem, geralmente, vários relógios em funcionamento ao mesmo momento, e combinam os seus dados.
- É também utilizado o sincronismo de relógios que funcionam em laboratórios distantes, utilizando métodos de comparação horária exatos e que possam ser operados em toda a Terra, em qualquer tempo.

Realização prática das Unidades do S.I.

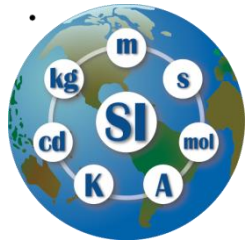

time

second, s: The second is the duration of 9 192 631 770 periods of the radiation corresponding to the transition between the two hyperfine levels of the ground state of the caesium 133 atom.

It follows that the hyperfine splitting in the ground state of the caesium 133 atom, $\nu(\text{hfs Cs})$, is 9 192 631 770 Hz exactly.

Tempo

- O sistema de satélite GPS fornece uma solução satisfatória para o sincronismo de relógios que funcionam em laboratórios distantes:
- composto de 24 satélites não geoestacionários, esse sistema é utilizado para o posicionamento, porém possui a particularidade de os satélites serem equipados com relógios de césio que difundem sinais horários, utilizados da seguinte maneira:

os relógios de dois laboratórios distantes são comparados com um relógio do satélite visível simultaneamente em ambos os laboratórios e é calculada a diferença.

Para uma comparação que se estende a, aproximadamente, dez minutos, a incerteza então obtida pode ser de poucos nanossegundo, mesmo para relógios que estão separados por milhares de quilómetro.

Realização prática das Unidades do S.I.

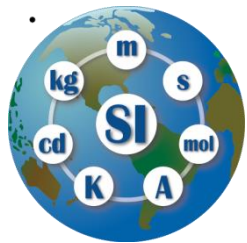

time

second, s: The second is the duration of 9 192 631 770 periods of the radiation corresponding to the transition between the two hyperfine levels of the ground state of the caesium 133 atom.

It follows that the hyperfine splitting in the ground state of the caesium 133 atom, $\nu(\text{hfs Cs})$, is 9 192 631 770 Hz exactly.

Tempo

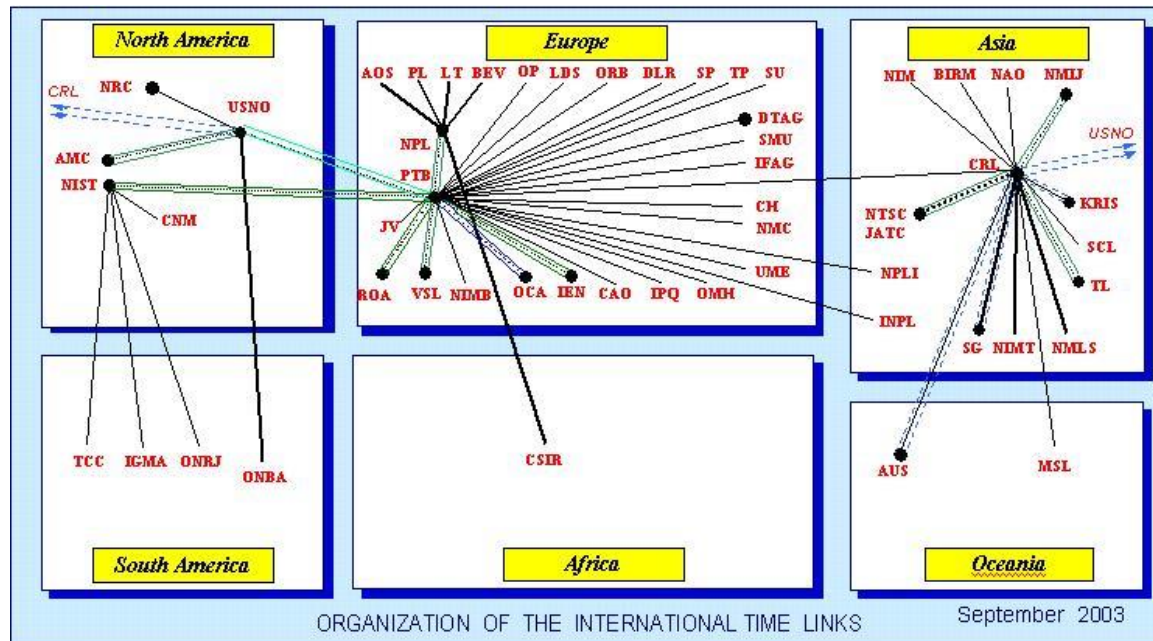

- TWSTFT
- - - TWSTFT back-up link
- · · TWSTFT link in preparation
- OCA/PTB link not used for computation of TAI
- Laboratory equipped with TWSTFT
- TWSTFT by Ku band with X band back-up
- GPS CV single-channel
- - - GPS CV single-channel back-up link
- GPS CV multi-channel
- · · GPS CV multi-channel back-up link



Realização prática das Unidades do S.I.

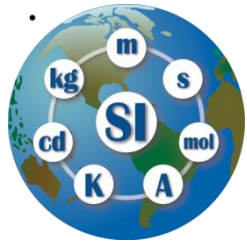

time

second, s: The second is the duration of 9 192 631 770 periods of the radiation corresponding to the transition between the two hyperfine levels of the ground state of the caesium 133 atom.

It follows that the hyperfine splitting in the ground state of the caesium 133 atom, $\nu(\text{hfs Cs})$, is 9 192 631 770 Hz exactly.

Tempo

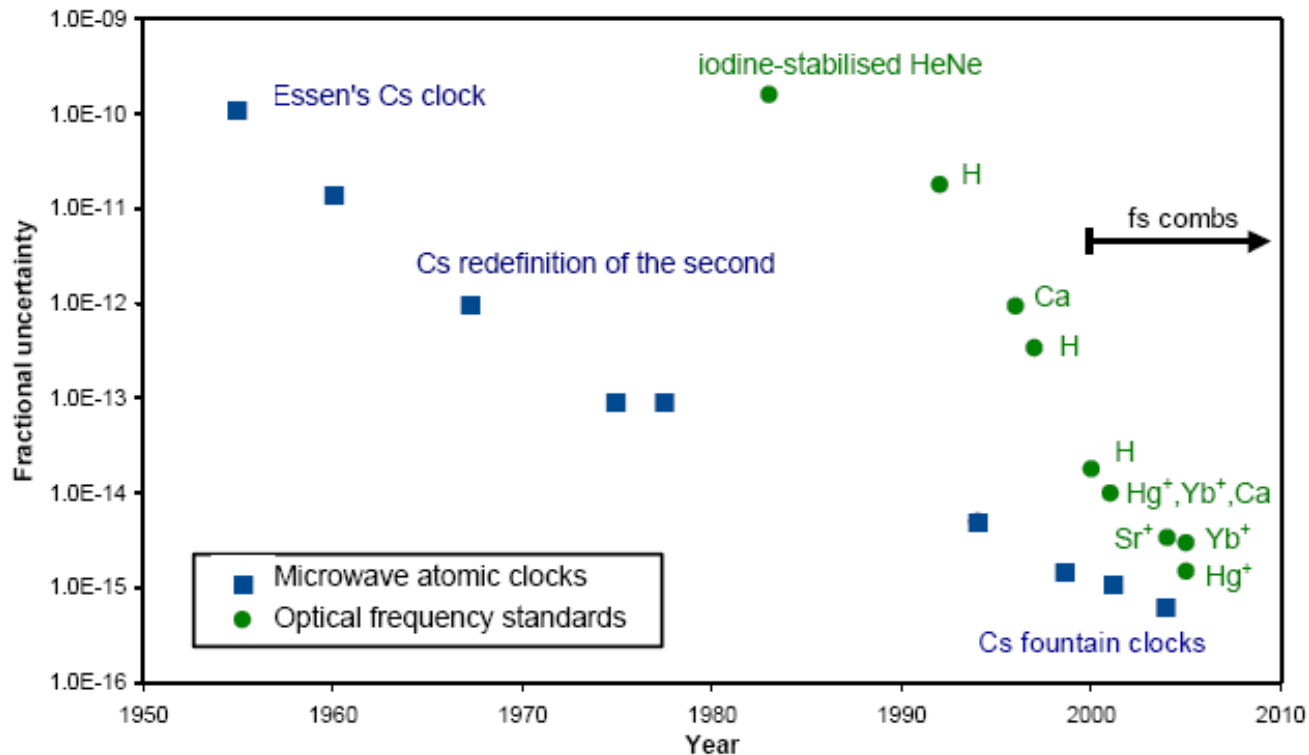

Figure 1: Improvements in atomic frequency standards

Gill & Riehle 2006

Realização prática das Unidades do S.I.



Search NPL...

Science +
Technology

Commercial
Services

Educate +
Explore

Joint Ventures

Publications

View Full
Menu



Home > News + Events > News

Accuracy of the NPL caesium fountain clock further improved

In 2011, the NPL caesium fountain primary frequency standard (NPL-CsF2) was hailed as the most accurate long-term timekeeper in the world, as it would lose or gain only one second in 138 million years. Now, this level of accuracy has been increased further: to one second in 158 million years.

NPL-CsF2 is one of the primary frequency standards most frequently used to calibrate the unit interval of the International Atomic Time (TAI) and Universal Coordinated Time (UTC) - the worldwide timescales used for global communications, satellite navigation and time stamping of financial transactions.

To improve the accuracy of the clock, NPL scientists make physical measurements and use mathematical models to evaluate and reduce any uncertainties within the system. One source of uncertainty is a frequency shift that occurs when a clock atom collides with an atom of background gas. As atomic clocks have become more accurate, this source of uncertainty has grown to become more significant.

Recent research from long-term collaborators at Penn State University in the USA produced a model to evaluate and reduce the systematic errors caused by these types of atom collisions. Further research from NPL scientists has used this model to evaluate the long term uncertainty of NPL-CsF2, resulting in a drop in this uncertainty from 2.3×10^{-16} to 2.0×10^{-16} . This new, lower uncertainty is equivalent to the clock losing or gaining one second in 158 million years.



NPL-CsF2 in the laboratory

Home

News + Events

- News

2.0×10^{-16}

1 s em 158 milhões de anos

<http://www.npl.co.uk/news/accuracy-of-the-npl-caesium-fountain-clock-further-improved>

18.02.2014

Krzysztof Szumaniec, who led the project at NPL, said:

Realização prática das Unidades do S.I.

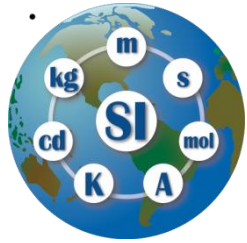

time

second, s: The second is the duration of 9 192 631 770 periods of the radiation corresponding to the transition between the two hyperfine levels of the ground state of the caesium 133 atom.

It follows that the hyperfine splitting in the ground state of the caesium 133 atom, $\nu(\text{hfs Cs})$, is 9 192 631 770 Hz exactly.

Tempo

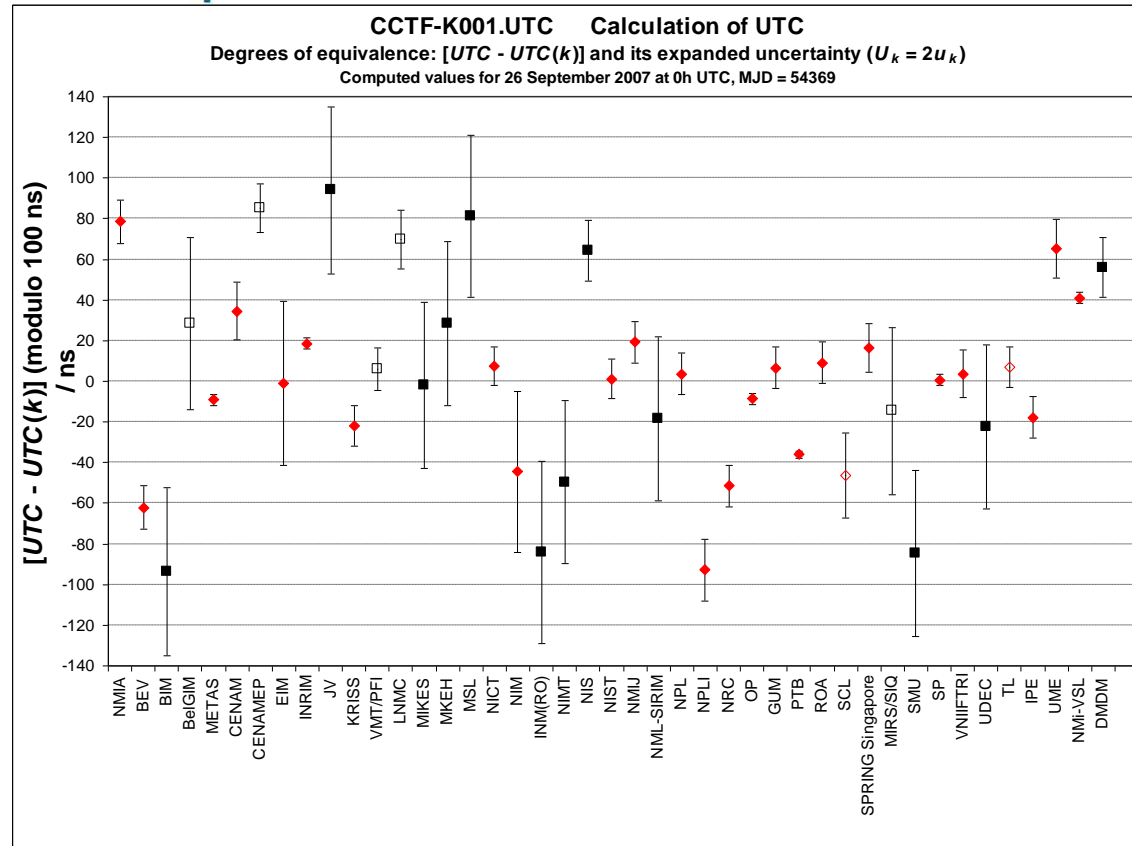

Realização prática das Unidades do S.I.

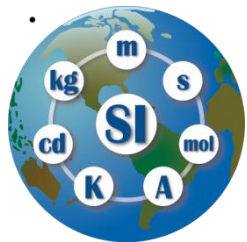

electric current

Corrente Eléctrica

ampere, A: The ampere is that constant current which, if maintained in two straight parallel conductors of infinite length, of negligible circular cross-section, and placed 1 metre apart in vacuum, would produce between these conductors a force equal to 2×10^{-7} newton per metre of length.

It follows that the magnetic constant, μ_0 , also known as the permeability of free space is $4\pi \times 10^{-7}$ H/m exactly.

- As melhores realizações atuais do ampère obtêm-se através de combinações de realizações do watt, do ohm e do volt.
- O watt, realizado de maneira elétrica, é comparado, com a ajuda de uma balança, com o watt realizado de maneira mecânica.
- O ohm é realizado utilizando-se a variação da capacidade de um condensador de Thompson-Lampard, variação que é unicamente função do deslocamento linear de um elétrodo.
- O volt é realizado por meio de uma balança na qual uma força eletrostática é medida em função de uma força mecânica.

Pode-se deduzir o ampère, combinando-se duas das três unidades anteriores.

A incerteza relativa do valor do ampère assim obtido é estimada em 10^{-7} .

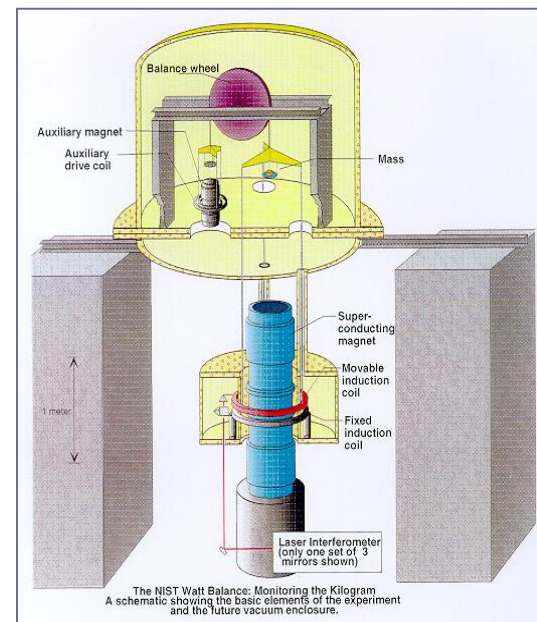

Realização prática das Unidades do S.I.

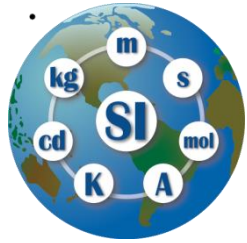

electric current

ampere, A: The ampere is that constant current which, if maintained in two straight parallel conductors of infinite length, of negligible circular cross-section, and placed 1 metre apart in vacuum, would produce between these conductors a force equal to 2×10^{-7} newton per metre of length.

It follows that the magnetic constant, μ_0 , also known as the permeability of free space is $4\pi \times 10^{-7}$ H/m exactly.

Corrente Eléctrica

- O ampére, o ohm e o volt podem também ser determinados a partir de medições de diversas combinações de constantes físicas.
- Os laboratórios utilizam, atualmente, padrões de referência do volt ou do ohm baseados, respetivamente, no efeito Josephson ou no efeito de Hall quântico, padrões que são nitidamente mais reprodutíveis e mais estáveis que 10^{-7} .
- A fim de aproveitar a vantagem que esses métodos mais estáveis oferecem para conservar os padrões de referência dos laboratórios que representam as unidades elétricas e tomando cuidado, ao mesmo tempo, para não modificar as definições do SI, a 18ª Conferência Geral adotou em 1987 a Resolução 6, que solicita que as representações do volt e do ohm sejam baseadas em valores, admitidos por convenção, da constante de Josephson, k_J , e da constante de von Klitzing, R_K .

Realização prática das Unidades do S.I.

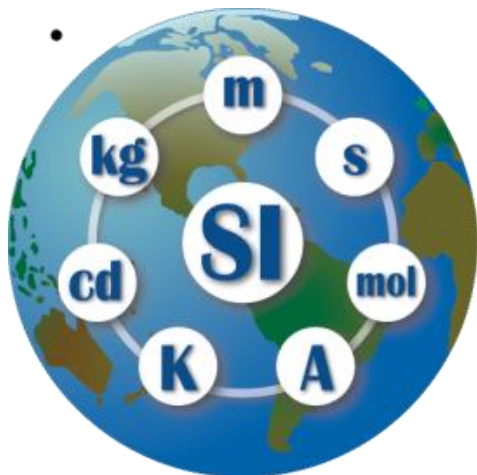

O ampère, o quilograma, o metro e o segundo determinam todas as demais grandezas elétricas.

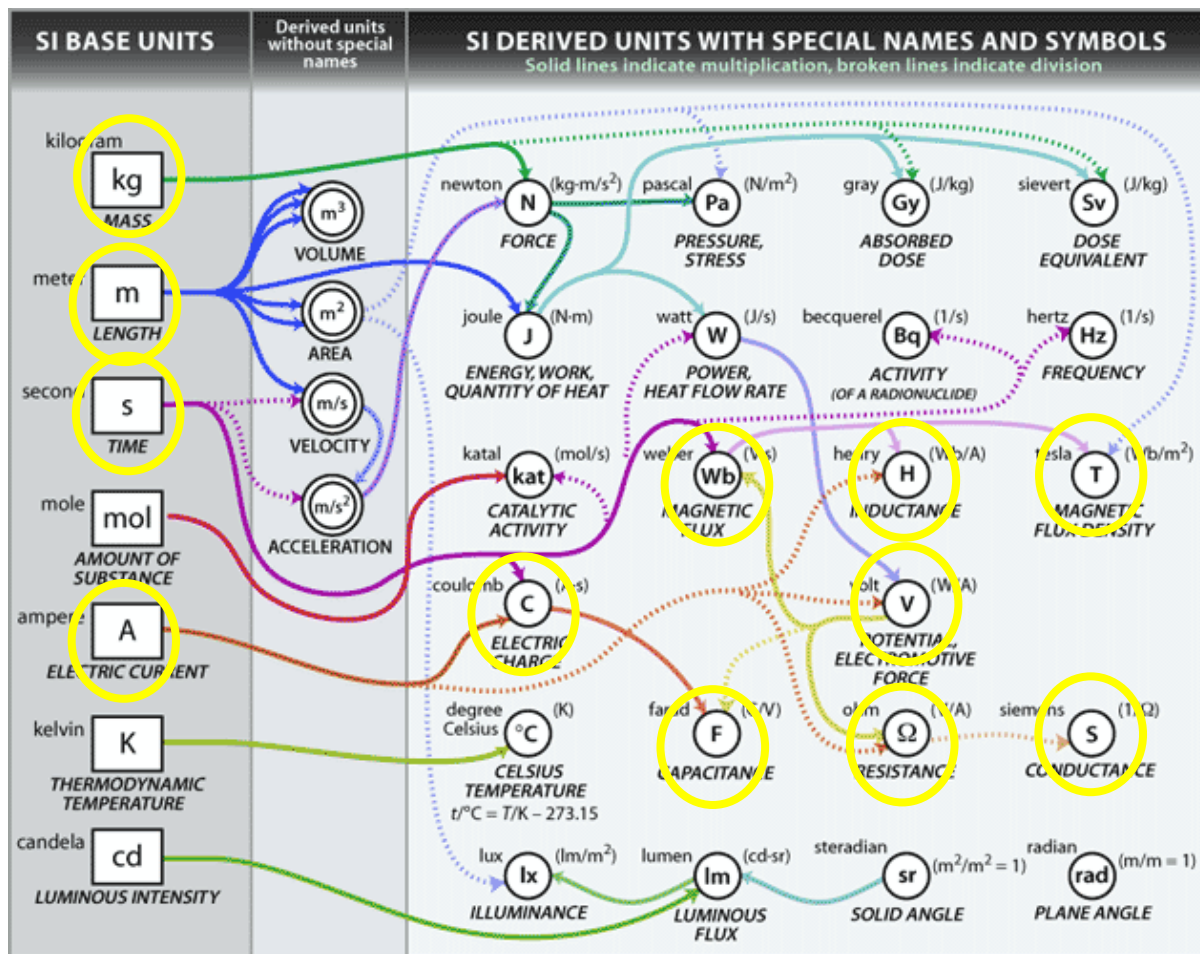

Realização prática das Unidades do S.I.



Search NPL...

Science +
Technology

Commercial
Services

Educate +
Explore

Joint Ventures

Publications

View Full
Menu

Home > News + Events > News

Record speed and accuracy achieved with single-electron pumps

The National Physical Laboratory (NPL), in collaboration with NTT (Nippon Telegraph and Telephone Corporation) in Japan, has measured silicon single-electron pumps with the highest speed and accuracy ever achieved, paving the way towards practical primary standards for electric current.

NTT's silicon nanodevice technology pushed the operating speed of the single-electron pumping frequency over 1 gigahertz (GHz), while the accuracy was verified to be better than one part per million using NPL's high-precision small-electric-current measurement system. The result was published in *Applied Physics Letters*

Single-electron pumps are tiny electronic devices that generate an electric current by moving individual electrons. These devices could be used as primary standards for the SI unit of electric current, the ampere. Presently, the definition of the ampere links it to the artefact kilogram, and there is no practical method to directly realise the ampere with the accuracy required for present-day electrical measurements.

The two key requirements of single-electron pumps are high accuracy and high speed.

Because the electrical charge of each electron is very small, a huge number of electrons need to be pumped within a given time to produce a usable current. At the same time, the exact number of electrons pumped in each cycle needs to be known to obtain an accurate value of the current. The difficulty is that high-speed



NTT's silicon single-electron device chip mounted on a sample holder for NPL's high-precision current measurement system

Home

News + Events

- News

$9,2 \times 10^{-7}$

<http://www.npl.co.uk/news/record-speed-and-accuracy-achieved-with-single-electron-pumps>

05.07.2016

Realização prática das Unidades do S.I.

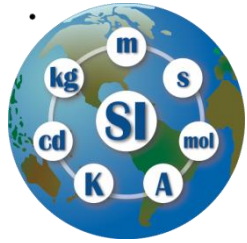

Temperatura Termodinâmica

thermodynamic temperature

kelvin, K: The kelvin, unit of thermodynamic temperature, is the fraction $1/273.16$ of the thermodynamic temperature of the triple point of water.

It follows that the thermodynamic temperature of the triple point of water, T_{tpw} , is 273.16 K exactly.

- Só podemos efetuar medições diretas da temperatura termodinâmica utilizando um dos raros termómetros chamados de primários. Estes são termómetros cuja equação de estado pode ser escrita de maneira explícita sem se ter que introduzir constantes desconhecidas que dependem da temperatura.
- Existem vários termómetros primários: o termómetro a gás de volume constante, o termómetro acústico a gás, os termómetros de radiação espectral ou total e o termómetro eletrónico a ruído.
- Com esses termómetros foram obtidas incertezas de poucos mK até, aproximadamente, 373 K; acima, as incertezas aumentam progressivamente.
- Existem termómetros secundários, como os termómetros de resistência de platina, com os quais a reprodutibilidade das medições pode ser da ordem de dez vezes superior às medições efetuadas com um dos termómetros primários.

Realização prática das Unidades do S.I.

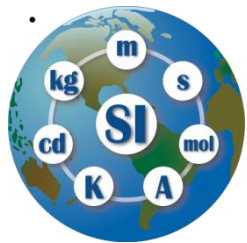

Temperatura Termodinâmica

thermodynamic temperature

kelvin, K: The kelvin, unit of thermodynamic temperature, is the fraction $1/273.16$ of the thermodynamic temperature of the triple point of water.

It follows that the thermodynamic temperature of the triple point of water, T_{tpw} , is 273.16 K exactly.

- A 19ª Conferência Geral (1991, Resolução 3) recomendou aos laboratórios nacionais empreenderem esforços a fim de aprimorar a uniformidade mundial e a estabilidade a longo termo das medições de temperatura, implementando rapidamente a EIT-90 (escala internacional de temperatura).
- A EIT-90 estende-se de 0,65 K até a temperatura mais elevada mensurável por meio de um pirómetro ótico. A escala baseia-se em:
 1. uma série de pontos fixos de definição; e
 2. métodos de interpolação a serem utilizados entre esses pontos.
- Os pontos fixos de definição são as temperaturas de um determinado número de estados termodinâmicos, realizáveis de maneira experimental.
- As interpolações são definidas entre 0,65 K e 5 K, por meio de equações da pressão de vapor saturante de hélio; entre 3 K e 24,5561 K, por meio do termómetro de interpolação a gás de volume constante; entre 13,8033 K e 961,78 °C, por meio do termómetro de resistência de platina; e, nas temperaturas superiores, por meio da lei da radiação ionizante de Planck.

Realização prática das Unidades do S.I.

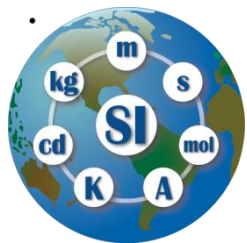

amount of substance

mole, mol:

1. The mole is the amount of substance of a system which contains as many elementary entities as there are atoms in 0.012 kilogram of carbon 12.
2. When the mole is used, the elementary entities must be specified and may be atoms, molecules, ions, electrons, other particles, or specified groups of such particles.

Quantidade de matéria

It follows that the molar mass of carbon 12, $M(^{12}\text{C})$, is 12 g/mol exactly.

- Todos os resultados quantitativos de análises químicas (ou dosagens) podem ser expressos em unidades de quantidade de matéria de partículas constituintes, cuja unidade é o mol.
- O princípio das medidas físicas baseadas na mol é o seguinte:
- considere-se uma amostra de um corpo puro constituído por átomos; chamemos de X o símbolo químico desses átomos:
- Um mol de átomos X contém por definição tantos átomos dessa substância quantos átomos de ^{12}C existam em 0,012 kg de carbono 12.
- Como não se sabe medir com exatidão a massa $m(^{12}\text{C})$ de um átomo de carbono 12, nem a massa $m(\text{X})$ de um átomo X, utiliza-se a relação entre essas massas $m(\text{X}) / m(^{12}\text{C})$, que pode ser determinada com exatidão, por exemplo, por meio de uma armadilha de Penning*.
- A massa correspondente a 1 mol de X é, então $[m(\text{X}) / m(^{12}\text{C})] \times 0,012$ kg,

*Armadilhas de Penning são dispositivos para o armazenamento de partículas carregadas, utilizando um campo magnético estático homogéneo e um campo elétrico estático não homogéneo espacialmente.

Realização prática das Unidades do S.I.

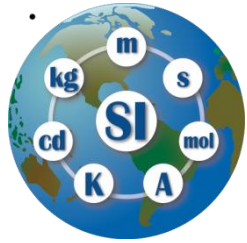

luminous intensity

candela, cd: The candela is the luminous intensity, in a given direction, of a source that emits monochromatic radiation of frequency 540×10^{12} hertz and that has a radiant intensity in that direction of $1/683$ watt per steradian.

It follows that the spectral luminous efficacy, K , for monochromatic radiation of frequency 540×10^{12} Hz is 683 lm/W exactly.

Intensidade luminosa

- A definição da candela é expressa em termos estritamente físicos.
- O objetivo da fotometria, todavia, é o de medir a luz de uma maneira tal que o resultado da medição expresse exatamente a sensação visual de um observador humano.
- Com esse objetivo, a CIE (Comissão Internationale de l'Eclairage) introduziu duas funções especiais $V(\lambda)$ e $V'(\lambda)$, ou funções de eficácia luminosa relativa espectral, que descrevem, respetivamente, a sensibilidade relativa espectral do olho humano médio em visão fotótica (adaptado à luz) ou escotópica (adaptado à escuridão).
- O Comité Internacional aprovou o uso dessas funções. Por conseguinte, as grandezas fotométricas correspondentes são definidas em termos estritamente físicos como grandezas proporcionais à integral de divisão espectral de potência, ponderada segundo uma função específica do comprimento de onda.

Realização prática das Unidades do S.I.

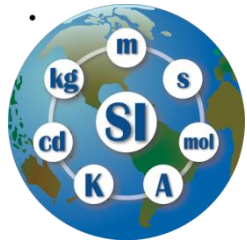

luminous intensity

candela, cd: The candela is the luminous intensity, in a given direction, of a source that emits monochromatic radiation of frequency 540×10^{12} hertz and that has a radiant intensity in that direction of 1/683 watt per steradian.

It follows that the spectral luminous efficacy, K , for monochromatic radiation of frequency 540×10^{12} Hz is 683 lm/W exactly.

Intensidade luminosa

- Os primeiros padrões fotométricos eram fontes luminosas; os mais antigos eram as velas (candles), daí o nome de candela para a unidade fotométrica de base.
- De 1948 a 1979, a radiação de um corpo negro à temperatura de congelamento da platina era utilizada para definir a candela.
- Atualmente, os laboratórios nacionais de metrologia realizam a candela por meio de métodos radiométricos. Entretanto, as lâmpadas-padrão são sempre utilizadas para conservar as unidades fotométricas: elas fornecem, ou uma intensidade conhecida, numa certa direção, ou um fluxo luminoso conhecido.
- O valor 1/683 watt por esterradiano que figura na definição atual foi escolhido em 1979 para reduzir, ao máximo, as variações das realizações médias das unidades fotométricas conservadas nos laboratórios nacionais.
- A definição não fornece nenhuma indicação da maneira como a candela deve ser realizada, o que apresenta a grande vantagem de permitir que se adotem novas técnicas para realizar a candela sem se alterar a definição da unidade de base.

Realização prática das Unidades do S.I.

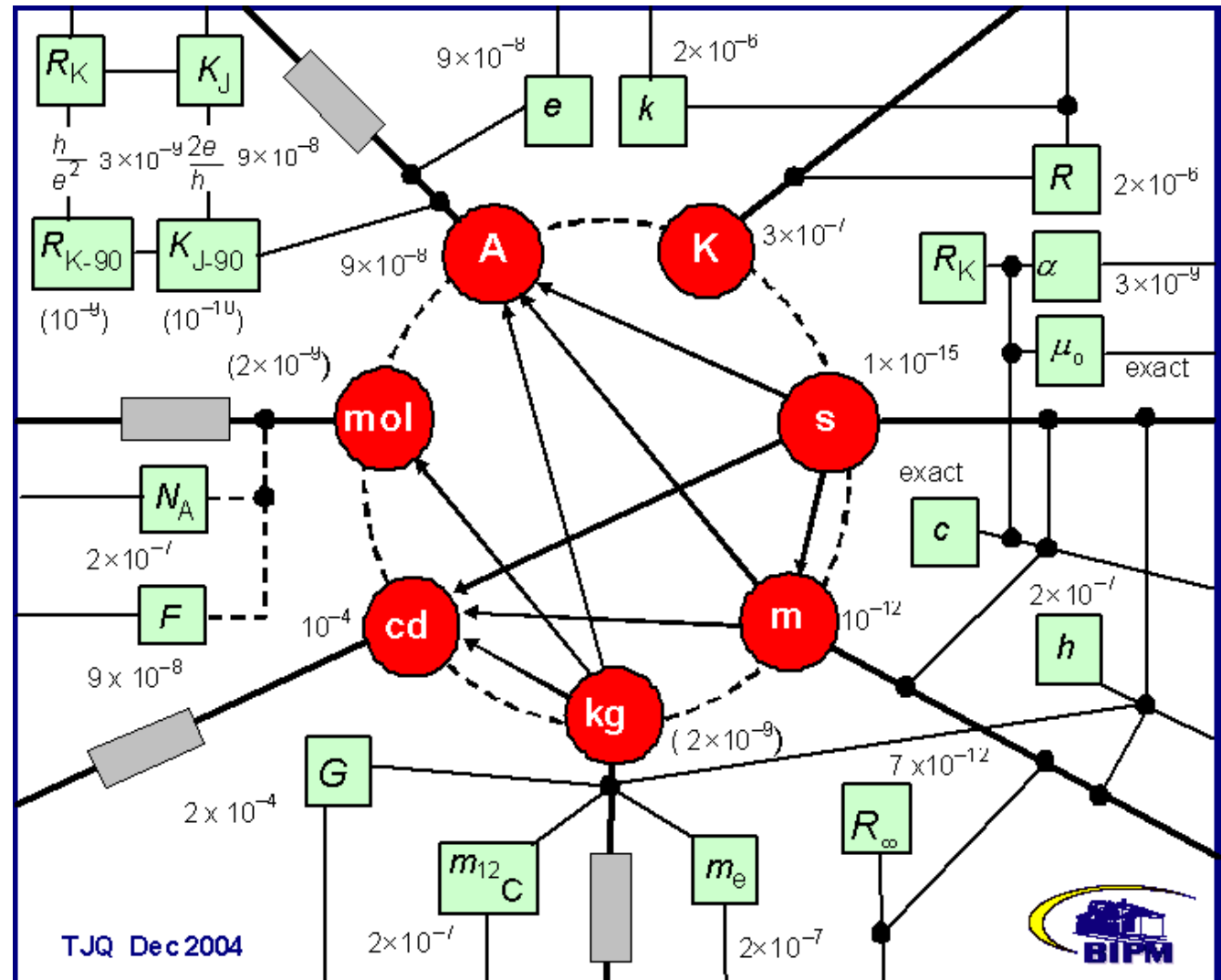
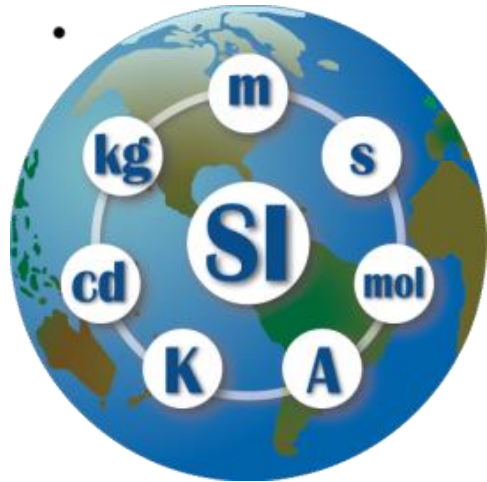

O Futuro do Sistema Internacional



É necessário mudar o Sistema Internacional?

- A última revisão importante do sistema métrico foi em 1960 quando o Sistema Internacional de Unidades (SI) foi formalmente publicado como um conjunto coerente de unidades de medida.
- Das sete unidades de base do SI, apenas o kg ainda é definido em termos de um artefacto material, o protótipo internacional mantido na BIPM.
- A presente definição do kg refere-se à massa do artefacto que, pela sua própria natureza, não pode ser absolutamente estável.
- Mudanças desconhecidas na unidade de massa também influenciam as unidades elétricas, porque a definição do ampère está relacionada com a do kg.
- O mesmo se passa com as definições da mole e da candela (também dependem do kg).

... SIM !

O Futuro do Sistema Internacional



- No final de 2011, a Conferência Geral de Pesos e Medidas (CGPM) adotou uma resolução no seguimento da proposta de revisão das definições formais das unidades SI por parte do Comité Internacional de Pesos e Medidas (CIPM).

Resolution 1 of the CGPM (2011): On the possible future revision of the International System of Units, the SI

- No novo SI, quatro das unidades SI de base: **quilograma**, **ampere**, **kelvin** e a **mole**; serão redefinidos sendo as novas definições baseadas em valores fixos e numéricos, respectivamente, da constante de **Planck** (h), a **carga elementar** (e), a **constante de Boltzmann** (k), e a **constante de Avogadro** (N_A).
- Além disso, as definições de todas as unidades de base sete do SI também serão expressas utilizando uma definição baseada em constantes.

O Futuro do Sistema Internacional



Em resumo, as alterações propostas são:

- Irão manter-se as mesmas sete unidades de base (metro, segundo, quilograma, ampere, kelvin, mol e candela).
- Destas, o quilograma, ampere, kelvin e a mole serão redefinidas escolhendo valores numéricos exatos para a constante de Planck, a carga elementar elétrica, a constante de Boltzmann, e a constante de Avogadro (respetivamente).
- O segundo o metro e a candela, são já definidos por constantes físicas e é apenas necessário rever as suas definições presentes.
- As novas definições irão melhorar o SI, sem alterar o tamanho de quaisquer unidades, garantindo assim a continuidade com as medidas atuais.

Projeto do Capítulo 2 da 9ª brochura do SI

(Draft dated 29 September 2010, produced by the CCU at its 20th meeting (2010))

http://www.bipm.org/utils/common/pdf/si_brochure_draft_ch2.pdf

O Futuro do Sistema Internacional

Projeto do Capítulo 2 da 9ª brochura do SI

(Draft dated 29 September 2010, produced by the CCU at its 20th meeting (2010))



➤ the International System of Units, the SI, will be the system of units in which:

- the ground state hyperfine splitting frequency of the caesium 133 atom $\Delta\nu(^{133}\text{Cs})_{\text{hfs}}$ is exactly 9 192 631 770 hertz,
- the speed of light in vacuum c is exactly 299 792 458 metre per second,
- the Planck constant h is exactly $6.626\ 06X \times 10^{-34}$ joule second,
- the elementary charge e is exactly $1.602\ 17X \times 10^{-19}$ coulomb,
- the Boltzmann constant k is exactly $1.380\ 6X \times 10^{-23}$ joule per kelvin,
- the Avogadro constant N_{A} is exactly $6.022\ 14X \times 10^{23}$ reciprocal mole,
- the luminous efficacy K_{cd} of monochromatic radiation of frequency 540×10^{12} Hz is exactly 683 lumen per watt,

where

(i) the hertz, joule, coulomb, lumen, and watt, with unit symbols Hz, J, C, lm, and W, respectively, are related to the units second, metre, kilogram, ampere, kelvin, mole, and candela, with unit symbols s, m, kg, A, K, mol, and cd, respectively, according to $\text{Hz} = \text{s}^{-1}$, $\text{J} = \text{m}^2 \text{kg s}^{-2}$, $\text{C} = \text{s A}$, $\text{lm} = \text{cd m}^2 \text{m}^{-2} = \text{cd sr}$, and $\text{W} = \text{m}^2 \text{kg s}^{-3}$,

(ii) the symbol X represents one or more additional digits to be added to the numerical values of h , e , k , and N_{A} , using values based on the most recent CODATA adjustment

Resolution 1 (CGPM 2011)

O Futuro do Sistema Internacional

Projeto do Capítulo 2 da 9ª brochura do SI

(Draft dated 29 September 2010, produced by the CCU at its 20th meeting (2010))



➔ the International System of Units, the SI, will be the system of units in which:

- the ground state hyperfine splitting frequency of the caesium-133 atom ν_{Cs} is exactly 9 192 631 770 hertz,
- the speed of light in vacuum c is exactly 299 792 458 metres per second,
- the Planck constant h is exactly $6.626\ 06X \times 10^{-34}$ joule second,
- the elementary charge e is exactly $1.602\ 17X \times 10^{-19}$ coulomb,
- the Boltzmann constant k is exactly $1.380\ 6X \times 10^{-23}$ joule per kelvin,
- the Avogadro constant N_{A} is exactly $6.022\ 14X \times 10^{23}$ reciprocal mole,
- the luminous efficacy K_{cd} of monochromatic radiation of frequency 540×10^{12} Hz is exactly 683 lumen per watt,

It is expected that in November 2018 the CGPM at its 26th meeting will adopt a revision of the SI in which:

- the Planck constant h is $6.626\ 070\ 15 \times 10^{-34}$ J s,
- the elementary charge e is $1.602\ 176\ 634 \times 10^{-19}$ C,
- the Boltzmann constant k is $1.380\ 649 \times 10^{-23}$ J/K,
- the Avogadro constant N_{A} is $6.022\ 140\ 76 \times 10^{23}$ mol⁻¹,

where

(i) the hertz, joule, coulomb, lumen, and watt, with unit symbols Hz, J, C, lm, and W, respectively, are related to the units second, metre, kilogram, ampere, kelvin, mole, and candela, with unit symbols s, m, kg, A, K, mol, and cd, respectively, according to $\text{Hz} = \text{s}^{-1}$, $\text{J} = \text{m}^2 \text{kg s}^{-2}$, $\text{C} = \text{s A}$, $\text{lm} = \text{cd m}^2 \text{m}^{-2} = \text{cd sr}$, and $\text{W} = \text{m}^2 \text{kg s}^{-3}$,

(ii) the symbol X represents one or more additional digits to be added to the numerical values of h , e , k , and N_{A} , using values based on the most recent CODATA adjustment

[Resolution 1 \(CGPM 2011\)](#)

O Futuro do Sistema Internacional

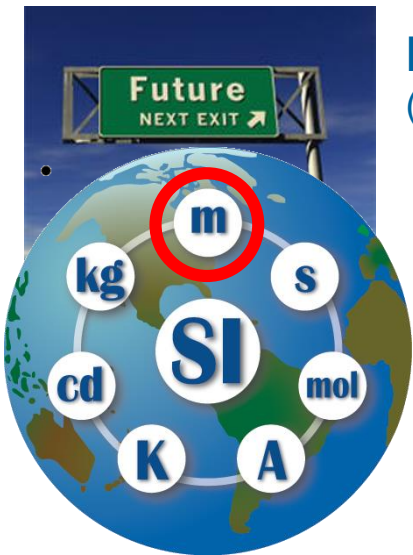

Projeto do Capítulo 2 da 9^o brochura do SI

(Draft dated 29 September 2010, produced by the CCU at its 20th meeting (2010))

Definição atual:

The metre is the length of the path travelled by light in vacuum during a time interval of $1/299792458$ of a second.



The metre, m, is the unit of length; its magnitude is set by fixing the numerical value of the speed of light in vacuum to be equal to exactly 299 792 458 when it is expressed in the unit $m s^{-1}$.

O Futuro do Sistema Internacional

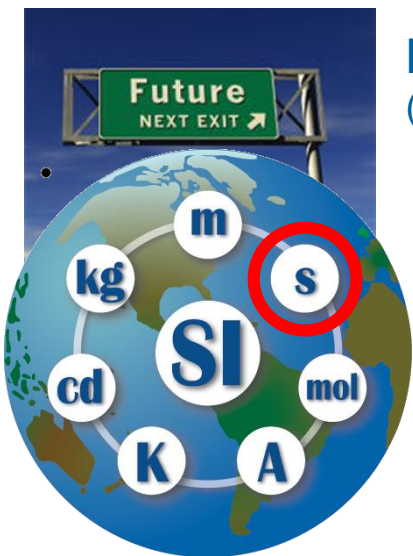

Projeto do Capítulo 2 da 9^o brochura do SI

(Draft dated 29 September 2010, produced by the CCU at its 20th meeting (2010))

Definição atual:

The second is the duration of 9192631770 periods of the radiation corresponding to the transition between the two hyperfine levels of the ground state of the caesium-133 atom.



The second, s, is the unit of time; its magnitude is set by fixing the numerical value of the ground state hyperfine splitting frequency of the caesium 133 atom, at rest and at a temperature of 0 K, to be equal to exactly 9 192 631 770 when it is expressed in the unit s^{-1} , which is equal to Hz.

O Futuro do Sistema Internacional

Projeto do Capítulo 2 da 9ª brochura do SI

(Draft dated 29 September 2010, produced by the CCU at its 20th meeting (2010))

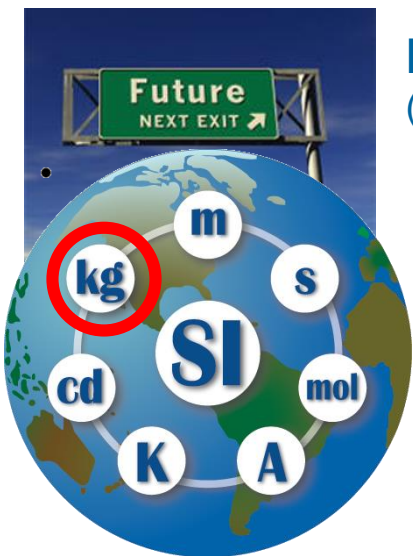

Definição atual:

The kilogram is the unit of mass; it is equal to the mass of the international prototype of the kilogram.



The kilogram, kg, is the unit of mass; its magnitude is set by fixing the numerical value of the Planck constant to be equal to exactly $6.626\ 068\ 96 \times 10^{-34}$ when it is expressed in the unit $\text{s}^{-1} \text{m}^2 \text{kg}$, which is equal to J s.

O Futuro do Sistema Internacional

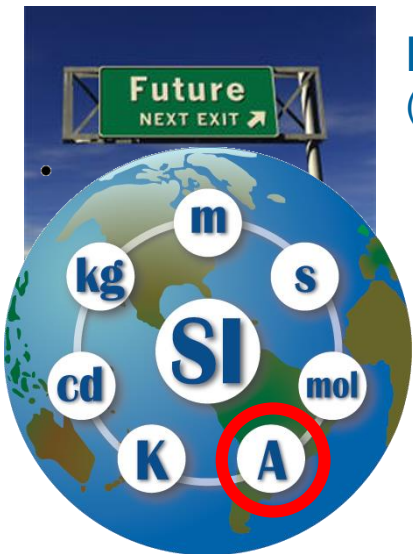

Projeto do Capítulo 2 da 9^o brochura do SI

(Draft dated 29 September 2010, produced by the CCU at its 20th meeting (2010))

Definição atual:

The ampere is that constant current which, if maintained in two straight parallel conductors of infinite length, of negligible circular cross-section, and placed 1 m apart in vacuum, would produce between these conductors a force equal to 2×10^{-7} newton per metre of length.



The ampere, A, is the unit of electric current; its magnitude is set by fixing the numerical value of the elementary charge to be equal to exactly $1.602\ 17 \times 10^{-19}$ when it is expressed in the unit s A, which is equal to C.

O Futuro do Sistema Internacional

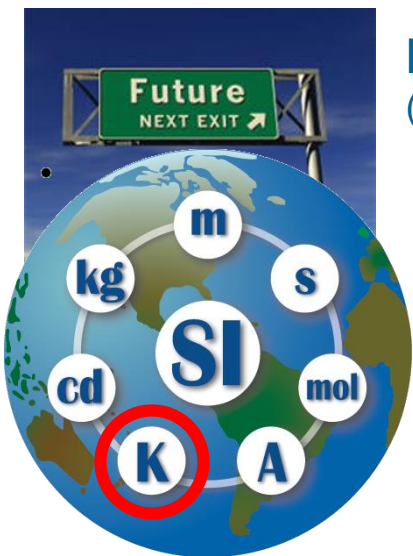

Projeto do Capítulo 2 da 9ª brochura do SI

(Draft dated 29 September 2010, produced by the CCU at its 20th meeting (2010))

Definição atual:

The kelvin, unit of thermodynamic temperature, is the fraction $1/273.16$ of the thermodynamic temperature of the triple point of water.



The kelvin, K, is the unit of thermodynamic temperature; its magnitude is set by fixing the numerical value of the Boltzmann constant to be equal to exactly $1.380\ 6X \times 10^{-23}$ when it is expressed in the unit $\text{s}^{-2} \text{m}^2 \text{kg K}^{-1}$, which is equal to J K^{-1} .

O Futuro do Sistema Internacional

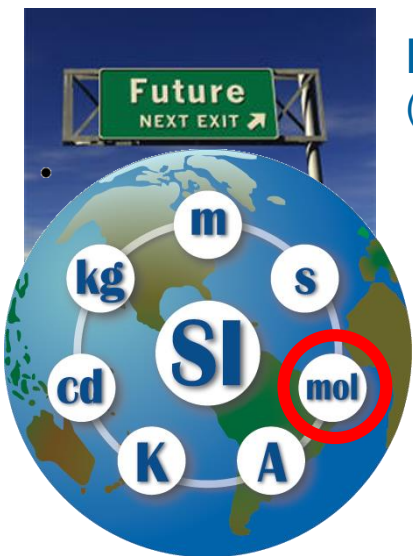

Projeto do Capítulo 2 da 9^o brochura do SI

(Draft dated 29 September 2010, produced by the CCU at its 20th meeting (2010))

Definição atual:

The mole is the amount of substance of a system which contains as many elementary entities as there are atoms in 0.012 kilogram of carbon-12. When the mole is used, the elementary entities must be specified and may be atoms, molecules, ions, electrons, other particles, or specified groups of such particles.



The mole, mol, is the unit of amount of substance of a specified elementary entity, which may be an atom, molecule, ion, electron, any other particle or a specified group of such particles; its magnitude is set by fixing the numerical value of the Avogadro constant to be equal to exactly $6.022\ 14\text{X} \times 10^{23}$ when it is expressed in the unit mol⁻¹.

O Futuro do Sistema Internacional

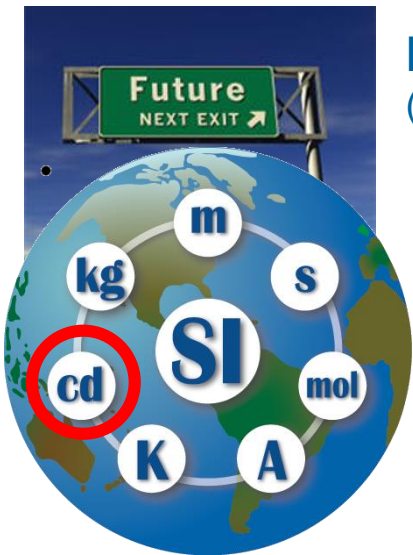

Projeto do Capítulo 2 da 9ª brochura do SI

(Draft dated 29 September 2010, produced by the CCU at its 20th meeting (2010))

Definição atual:

The candela is the luminous intensity, in a given direction, of a source that emits monochromatic radiation of frequency 540×10^{12} Hz and that has a radiant intensity in that direction of $1/683$ watt per steradian.

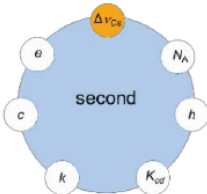
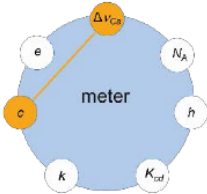
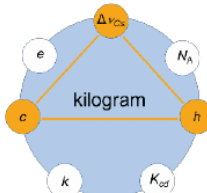
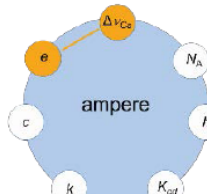

The candela, cd, is the unit of luminous intensity in a given direction; its magnitude is set by fixing the numerical value of the luminous efficacy of monochromatic radiation of frequency 540×10^{12} Hz to be equal to exactly 683 when it is expressed in the unit $\text{s}^3 \text{m}^{-2} \text{kg}^{-1} \text{cd sr}$, or cd sr W^{-1} , which is equal to lm W^{-1} .

Base unit	Definition	Conversion	Diagram
Second (s)	The second is the SI unit of time. It is defined by taking the fixed numerical value of the caesium frequency $\Delta\nu_{\text{Cs}}$, the unperturbed ground-state hyperfine transition frequency of the caesium 133 atom, to be 9 192 631 770 when expressed in the unit Hz, which is equal to s^{-1} .	$1 \text{ s} = 9\,192\,631\,770 / \Delta\nu_{\text{Cs}}$	
Meter (m)	The metre is the SI unit of length. It is defined by taking the fixed numerical value of the speed of light in vacuum c to be 299 792 458 when expressed in the unit m s^{-1} , where the second is defined in terms of the caesium frequency $\Delta\nu_{\text{Cs}}$.	$1 \text{ m} = (c / 299\,792\,458) \text{ s}$ $= 30.663\,318\dots c / \Delta\nu_{\text{Cs}}$	
Kilogram (kg)	The kilogram is the SI unit of mass. It is defined by taking the fixed numerical value of the Planck constant h to be $6.626\,070\,15 \times 10^{-34}$ when expressed in the unit J s , which is equal to $\text{kg m}^2 \text{ s}^{-1}$, where the metre and the second are defined in terms of c and $\Delta\nu_{\text{Cs}}$.	$1 \text{ kg} = (h / 6.626\,070\,15 \times 10^{-34}) \text{ m}^{-2} \text{ s}$ $= 1.475\,521\dots \times 10^{40} h \Delta\nu_{\text{Cs}} / c^2$	
Ampere (A)	The ampere is the SI unit of electric current. It is defined by taking the fixed numerical value of the elementary charge e to be $1.602\,176\,634 \times 10^{-19}$ when expressed in the unit C, which is equal to A s , where the second is defined in terms of $\Delta\nu_{\text{Cs}}$.	$1 \text{ A} = e / (1.602\,176\,634 \times 10^{-19}) \text{ s}^{-1}$ $= 6.789\,686\dots \times 10^8 \Delta\nu_{\text{Cs}} e$	

Base unit	Definition	Conversion	Diagram
Kelvin (K)	The kelvin is the SI unit of thermodynamic temperature. It is defined by taking the fixed numerical value of the Boltzmann constant k to be $1.380\,649 \times 10^{-23}$ when expressed in the unit J K^{-1} , which is equal to $\text{kg m}^2 \text{s}^{-2} \text{K}^{-1}$, where the kilogram, metre and second are defined in terms of h , c and ΔV_{Cs} .	$1 \text{ K} = (1.380\,649 \times 10^{-23}/k) \text{ kg m}^2 \text{ s}^{-2} = 2.266\,665\dots \Delta V_{\text{Cs}} h / k$	
Mole (mol)	The mole, symbol mol, is the SI unit of amount of substance. One mole contains exactly $6.022\,140\,76 \times 10^{23}$ elementary entities. This number is the fixed numerical value of the Avogadro constant, N_A , when expressed in the unit mol^{-1} and is called the Avogadro number. The amount of substance, symbol n , of a system is a measure of the number of specified elementary entities. An elementary entity may be an atom, a molecule, an ion, an electron, any other particle or specified group of particles.	$1 \text{ mol} = 6.022\,140\,76 \times 10^{23}/N_A$	
Candela (cd)	The candela is the SI unit of luminous intensity in a given direction. It is defined by taking the fixed numerical value of the luminous efficacy of monochromatic radiation of frequency 540×10^{12} Hz, K_{cd} , to be 683 when expressed in the unit lm W^{-1} , which is equal to cd sr W^{-1} , or $\text{cd sr kg}^{-1} \text{ m}^{-2} \text{ s}^3$, where the kilogram, metre and second are defined in terms of h , c and ΔV_{Cs} .	$1 \text{ cd} = (K_{\text{cd}}/683) \text{ kg m}^2 \text{ s}^{-3} \text{ sr}^{-1} = 2.614\,830\dots \times 10^{10} (\Delta V_{\text{Cs}})^2 h K_{\text{cd}}$	

O Futuro do Sistema Internacional

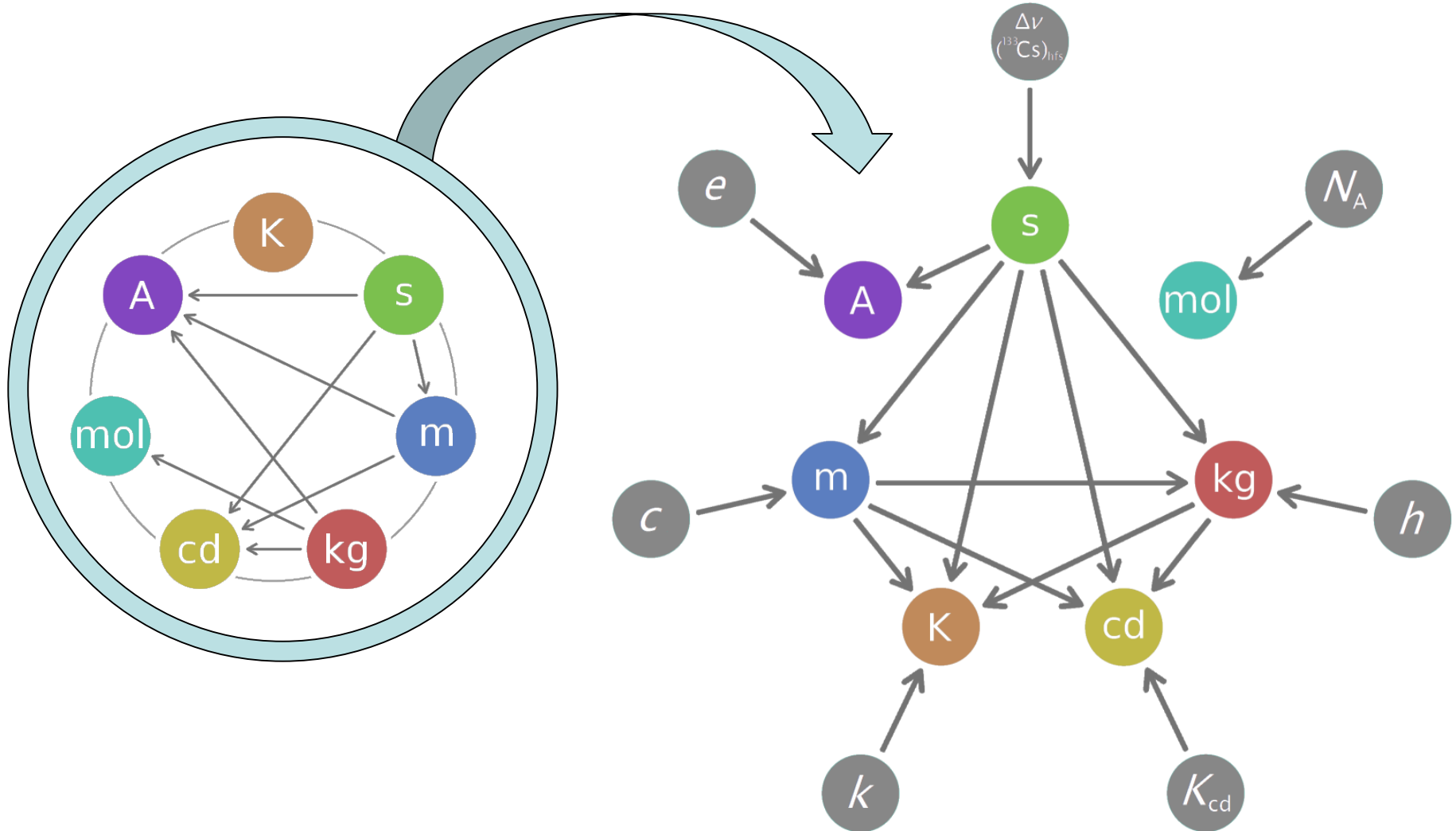

O Futuro do Sistema Internacional

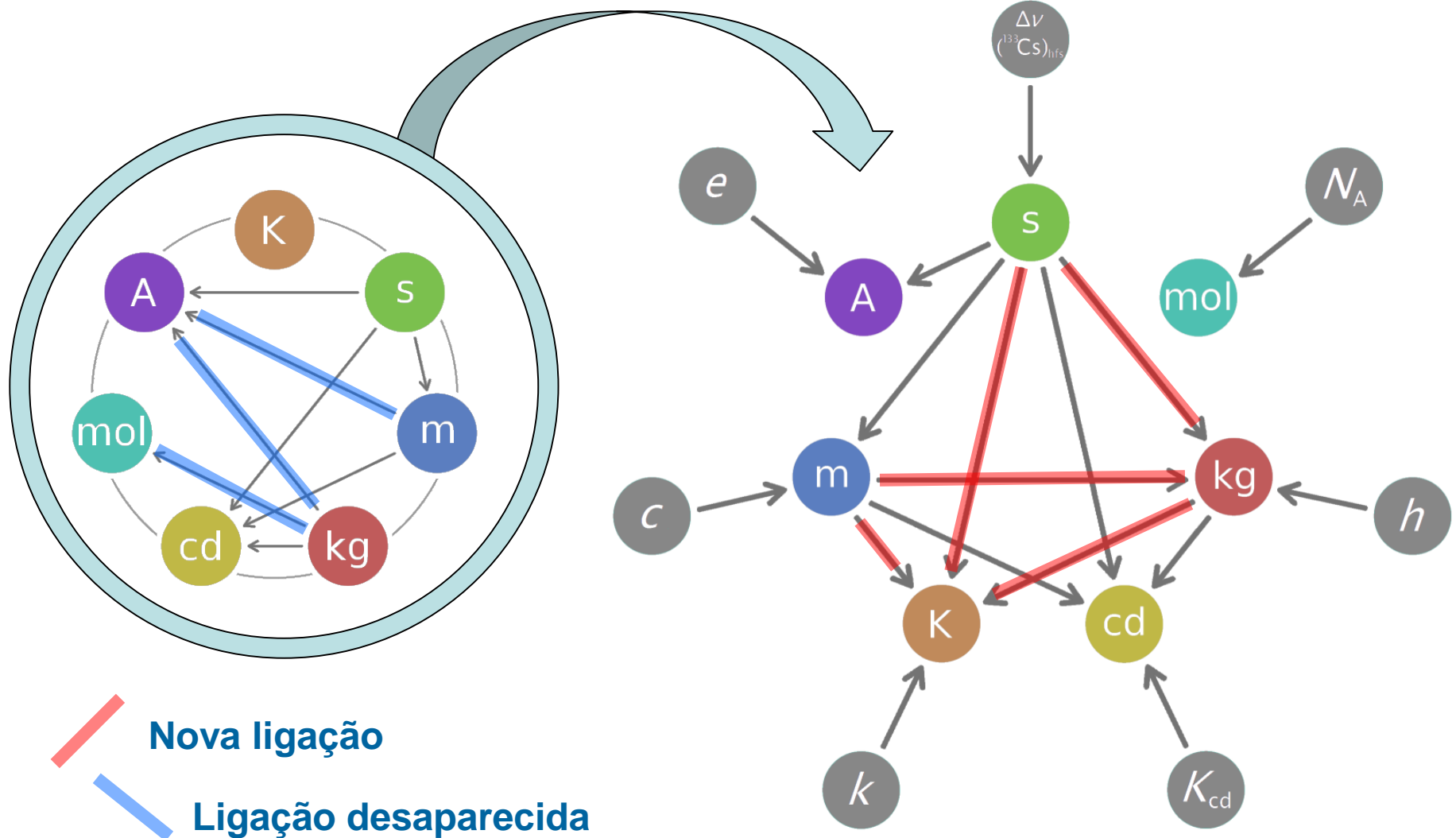

O Futuro do Sistema Internacional

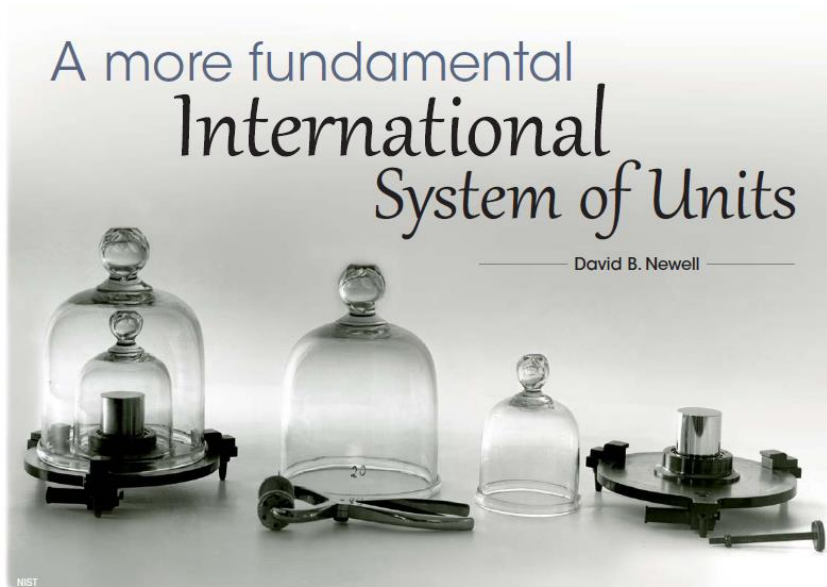

Impact and consequences

The impact of defining h , e , k , and N_A as exact will extend substantially beyond providing a basis for a system of units. Many other fundamental constants will simultaneously become exact due to the inherent relationships among them through the accepted laws of physics.

Another important consequence will be exact conversion factors, with no uncertainty, for expressing energy in units of joule, kilogram, inverse meter, hertz, kelvin, or electron volt. No longer will unit conversion cause an additional uncertainty component to appear—for example, when a researcher reports the mass of some particle in kilograms when in fact the measurement was in eV or hertz. In addition, many of the other fundamental constants will have substantially reduced uncertainties.

Table 3: Changing uncertainties for fundamental constants

Quantity	Symbol	Present SI $u_r \times 10^9$	New SI $u_r \times 10^9$
International prototype of the kilogram	$m(K)$	0	44
Permeability of free space	μ_0	0	0.32
Permittivity of free space	ϵ_0	0	0.32
Triple point of water	T_{TPW}	0	910
Molar mass of carbon-12	$M(^{12}C)$	0	0.70
Planck constant	h	44	0
Elementary charge	e	22	0
Boltzmann constant	k	910	0
Avogadro constant	N_A	44	0
Molar gas constant	R	910	0
Faraday constant	F	22	0
Stefan–Boltzmann constant	σ	3600	0
Electron mass	m_e	44	0.64
Atomic mass unit	m_u	44	0.70
Mass of carbon-12	$m(^{12}C)$	44	0.70
Josephson constant	K_J	22	0
von Klitzing constant	R_K	0.32	0
Fine-structure constant	α	0.32	0.32
$E = mc^2$ energy equivalent	J \leftrightarrow kg	0	0
$E = hc/\lambda$ energy equivalent	J \leftrightarrow m $^{-1}$	44	0
$E = h\nu$ energy equivalent	J \leftrightarrow Hz	44	0
$E = kT$ energy equivalent	J \leftrightarrow K	910	0
1 J = 1 (C/e) eV energy equivalent	J \leftrightarrow eV	22	0

O Futuro do Sistema Internacional

New SI FAQs (from BIPM)

So what is the point of changing to new definitions?

- Defining the kilogram in terms of fundamental physical constants will ensure its long-term stability, and hence its reliability, which is at present in doubt.
- The new definitions of the ampere and kelvin will significantly improve the accuracy with which mass, electrical, and radiometric temperature measurements can be made.
- The impact on electrical measurements will be immediate: the most precise electrical measurements are always made using the Josephson and quantum Hall effects, and fixing the numerical values of h and e in the new units will lead to exactly known values for the Josephson and von Klitzing constants.
- The conversion factor between measured radiance and thermodynamic temperature (the Stefan-Boltzmann constant) will be exact using the new definitions of the kelvin and kilogram, leading to improved temperature metrology as technology improves.
- The revised definition of the mole is simpler than the current definition, and it will help users of the SI to better understand the nature of the quantity "amount of substance" and its unit, the mole.

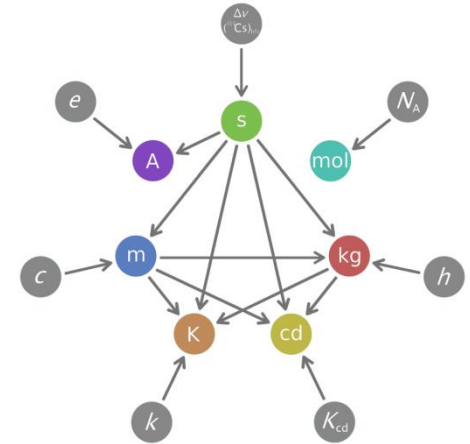

O Futuro do Sistema Internacional

New SI FAQs (from BIPM)

How can you fix the value of a fundamental constant like h to define the kilogram, and e to define the ampere, and so on? How do you know what value to fix them to? What if it emerges that you have chosen the wrong value?

- We do not fix – or change – the value of any constant that we use to define a unit. The values of the fundamental constants are constants of nature and we only fix the numerical value of each constant when expressed in the New SI unit.
- Example: If c is the value of the speed of light, $\{c\}$ is its numerical value, and $[c]$ is the unit, so that
$$c = \{c\}[c] = 299\,792\,458 \text{ m/s}$$

then the value c is the product of the number $\{c\}$ times the unit $[c]$, and the value never changes. However the factors $\{c\}$ and $[c]$ may be chosen in different ways such that the product c remains unchanged.

- In 1983 it was decided to fix the number $\{c\}$ to be exactly 299 792 458, which then defined the unit of speed $[c] = \text{m/s}$. Since the second, s , was already defined, the effect was to define the metre, m . The number $\{c\}$ in the new definition was chosen so that the magnitude of the unit m/s was unchanged, thereby ensuring continuity between the new and old units.

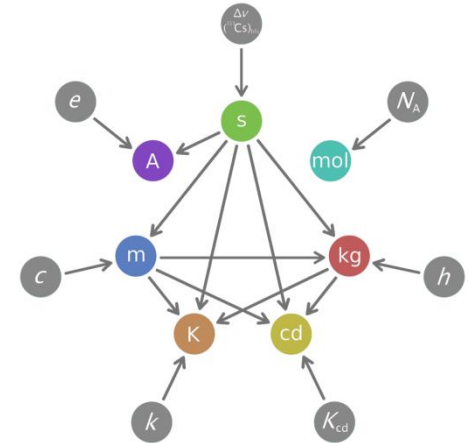

O Futuro do Sistema Internacional

New SI FAQs (from BIPM)

Each of the fundamental constants used to define a unit has an uncertainty; its value is not known exactly. But it is proposed to fix its numerical value exactly. How can you do that? What has happened to the uncertainty?

- The present definition of the kilogram fixes the mass of the IPK to be one kilogram exactly with zero uncertainty, $ur(m_{\text{IPK}}) = 0$.
- The Planck constant is at present experimentally determined, and has a relative standard uncertainty of 4.4 parts in 10^8 , $ur(h) = 4.4 \times 10^{-8}$.
- In the new definition the value of h would be known exactly in the new units, with zero uncertainty, $ur(h) = 0$.
- But the mass of the IPK would have to be experimentally determined, and it would have a relative uncertainty of about $ur(m_{\text{IPK}}) = 4.4 \times 10^{-8}$.
- Thus the uncertainty is not lost in the new definition, but it moves to become the uncertainty of the previous reference that is no longer used.

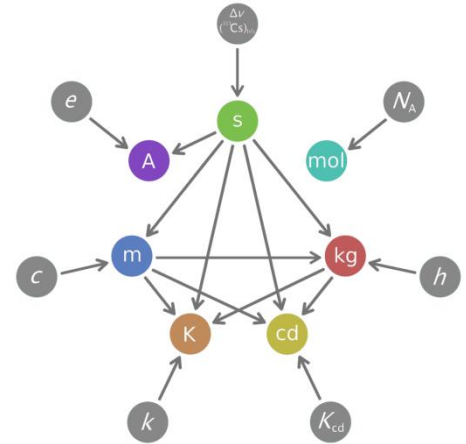

O Futuro do Sistema Internacional

New SI FAQs (from BIPM)

Can we still check the consistency of physics if we fix the values of all the fundamental constants?

- We are not fixing the values of all the fundamental constants, only the numerical values of a small subset and combinations of the constants in this subset.
- This has the effect of changing the definitions of the units, but not the equations of physics, and it cannot prevent researchers from checking the consistency of the equations.

